



## **Toll4Europe 4G On-Board Unit** Operating instructions

07/03/2025  
Version 1.0 | GM 4.9

## Intended Use

The Toll4Europe On-Board-Unit (T4E-OBU) is intended to be used for electronic toll collection and other telematics services and shall be used for this purposes exclusively unless other uses are expressly permitted. Any other use will be considered to be prohibited misuse and would lead to a waiver of all claims.

## Safety notes



### General instructions

Do not use any objects with acute points or sharp edges for operating the OBU. Use only cloths moistened with water for cleaning. Do not use solvents or aggressive cleaning agents. Damaged power cables must be replaced immediately to avoid short circuits or fires.



### Use in potentially explosive atmosphere

Using the OBU in potentially explosive atmosphere is generally not permitted.



### Risk caused by (rechargeable) batteries

Protect the battery against the impact of mechanical forces (shock, drop, vibration) and temperatures  $> +85\text{ °C}$  since this may cause a fire. For more safety information and instructions see the detailed operating instructions.

















### Environmental protection

Devices returned to us go through a comprehensive refurbishment process. Do not remove the battery from the OBU. It is needed for this process. Always return the complete OBU to your Service Partner. Contact your Service Partner for more information.

# Contents

<b>Contents</b>	<b>3</b>
<b>List of Abbreviations</b>	<b>6</b>
<b>List of Symbols</b>	<b>7</b>
<b>Toll collection in EETS domains</b>	<b>8</b>
1.1    General information on the EETS	8
1.2    EETS and Toll4Europe	9
<b>Package content</b>	<b>11</b>
<b>Installation and mounting of the OBU</b>	<b>12</b>
3.1    Installation of the OBU	12
3.1.1    Fixed installation	12
3.1.2    Flexible installation	14
3.1.3    Exchange of the Yunex C3080 OBU for the Norbit VTP-1425 OBU	15
3.2    Mounting the OBU on the windshield	15
3.3    Mounting the OBU on the windshield	17
<b>Quick start</b>	<b>19</b>
4.1    Requirements while driving	19
4.2    First use of the OBU	20
4.3    Main screen	21
4.4    Status indicator	22
4.5    Menu navigation	23
4.6    Language selection	24
<b>Configuration</b>	<b>25</b>
5.1    Changeable OBU parameters	25
5.2    Trailer axles	29
5.3    Current weight	30
5.4    Configuration for Switzerland CHlsv	31
5.4.1    Entering the trailer weight	31
5.4.2    Transport mode	32
<b>Driver information and additional functions of the OBU</b>	<b>34</b>
6.1    Booked toll services	34
6.2    Vehicle parameters	34
6.3    Additional services	35



























<b>Driving with the OBU</b>	<b>36</b>
7.1 Starting the engine	36
7.2 Modes of operation	38
7.3 Indication of information on the OBU	39
7.4 Toll lanes	41
7.5 Examples for driving through various EETS domains	43
<b>Error management and emergency procedures</b>	<b>45</b>
8.1 Error detection and trouble shooting	45
8.2 Alternative payment methods	47
8.3 Customer service	49
<b>Specific features of individual toll domains</b>	<b>50</b>
9.1  Belgium (BEvia)	50
9.2  Belgium Liefkenshoek-Tunnel (BELit)	50
9.3  Bulgaria (BGria)	51
9.4  Denmark and Sweden	51
9.5  Germany (DEbag)	52
9.6  Germany Herrentunnel and Warnow tunnel (DEtun)	54
9.7  France (FRtis)	55
9.8  Italy (ITsit)	56
9.9  Austria (ATasf)	58
9.10  Polen (PLEto)	59
9.11  Portugal (PTvve) and Spain (ESvia)	60
9.12  Switzerland (CHlsv)	61
9.13  Slovakia (SKmyt)	62
9.14  Slovenia (Slidar)	63
9.15  Hungary (HUgo)	63

<b>OBU-User Interface</b>	<b>65</b>
10.1    Menu Structure	65
10.2    Settings	66
10.3    Show OBU information and software version	68
<b>Technical Data</b>	<b>70</b>
<b>Conformity declaration</b>	<b>70</b>

# List of Abbreviations

ADR	Accord européen relatif au transport international des marchandises dangereuses par route (European Agreement concerning the International Carriage of Dangerous Goods by Road)
DSRC	Dedicated Short Range Communication
EETS	European Electronic Toll Service
GNSS	Global Navigation Satellite System
GVW	Gross Vehicle Weight
T4E	Toll4Europe
OBU	On-Board Unit

# List of Symbols

	Axles		Select
	Weight		Telephone
	Warning		Battery status
	Bluetooth is on		Battery is fully charged
	Bluetooth coupling		Battery is being charged
	Delete		Battery charge is low
	Mobile phone signal		Sleep mode
	GNSS signal		Wait
	Confirm		Off
	Back		Wake up
	Close		Cash
	Continue		Credit card or fuel card
	Navigation wheel		Ticket
			Online

# 01/

## Toll collection in EETS domains

The service provider Toll4Europe GmbH (T4E) offers its EETS Service for the users of vehicles subject to toll in Europe.

The EETS-enabled OBU provided by T4E makes it easier to use the roads that are subject to toll all over Europe because a comprehensive toll collection and payment service is managed by a single device.

### 1.1 General information on the EETS

Depending on the regulations that apply for the individual European toll domains the OBU can be used on trucks with a gross vehicle weight (GVW) of 3.5 t or more for toll collection on motorways and/or provincial and regional roads, tunnels and bridges. Our T4E-OBUs:

- is used for determining on which sections or over how many kilometres the vehicle was driven in the toll domain; a toll domain is either the entire network of roads subject to toll in a country or a specific part of the roads subject to toll in a country (roads, tunnels, bridges);
- is able to cover many toll domains in Europe and thus collects the data relevant for toll collection across national border;
- is installed in vehicles to determine whether a road used is subject to toll;
- collects the data relevant for toll collection and transmits them to a data centre where they are processed for invoicing;
- is linked with the vehicle for which EETS Services can be subscribed in one or more toll domains.



In case a particular toll domain is not yet covered by the EETS Service offered by T4E or the T4E service was not booked, the user can also operate additional national OBUs. However, before changing from a national toll provider to the EETS Service, the national OBU must be switched off or removed before the T4E-OBU is used for that particular toll domain. T4E is not liable in case toll is charged twice for the same trip.

## 1.2 EETS and Toll4Europe

Our T4E-OBU fulfils the toll regulations of the national/regional authorities and enables the user to cross borders nonstop since it is compatible with various technical systems in different toll domains (GNSS and/or DSRC).

The EETS Service offered by T4E can be booked for one or several countries (as “toll service” for specific toll domains). We continuously expand the coverage of the toll services that can be booked through T4E. However, in each toll domain only one OBU must be used per vehicle to avoid having to pay too much toll.

The road users are obliged to find out if their vehicles are subject to toll and which regulations or exceptions apply in the individual toll domains. The relevant regulations are given in the national toll laws.

















First the users have to register with a T4E Sales and Service Partner. When registering for the EETS Services provided by T4E, the user or the transport company have to select the toll services they intend to use in the toll domains where they intend to use the roads. When registering, the user or transport company have to provide the required customer and vehicle data. The Sales and Service Partners ensure registration and allocate an OBU to each vehicle. As soon as all necessary data were transferred to the system, the OBU can be personalized for use. Personalization comprises an update of the OBU with the necessary software, the user and the vehicle data and with the toll data. The update is carried out “wireless” through a mobile network when the OBU has been installed in the vehicle and is connected with the power supply.



In some selected toll domains the driver is obliged to first check himself some variable data in the OBU (i.e. the number of trailer axles permissible, the total weight of the vehicle including the trailer) before beginning to use the roads of the toll domain. The permissible total weight of the vehicle including the trailer is the maximum permissible total weight of the tractor together with the trailer coupled with it at that particular moment.

The following chapters provide a detailed description of the operation of the OBU and how to enter the specific parameters required in each toll domain.

The following EETS Services can be booked and more will be added in future. The OBU will show them in the following way:

	Belgium (Viapass)	BEvia
	Belgium (Liefkenshoektunnel)	BEliT
	Bulgaria (RIA)	BGria
	Denmark (Storebælt bridge and Øresund bridge)	DKbri
	Germany (BAG)	DEbag
	Germany (Warnowquerung (Warnow tunnel) and Herrentunnel)	DEtun
	France (ASFA)	FRtis
	Italy (AISCAT)	ITsit
	Austria (ASFINAG)	ATasf
	Poland (KAS - state toll roads)	PLeto
	Portugal (APCAP)	PTve
	Switzerland (BAZG)	CHIsv
	Slovakia (NDS)	SKmyt
	Slovenia (DARS)	Sldar
	Spain (SEOPAN)	ESvia
	Hungary (NUSZ)	HUgo

# 02/

## Package content

Take the OBU out of the box. Check if the content of the package is complete and undamaged.

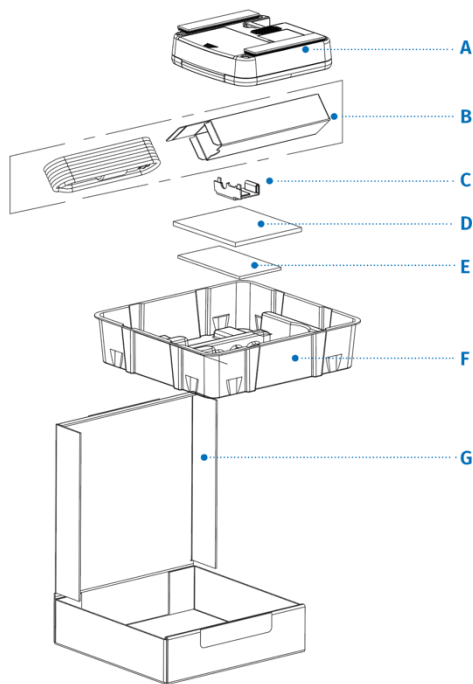

- A 4G On-Board Unit
- B Power cable
- C Power cable cover
- D Quick Start Guide
- E Wipe
- F Packaging tray
- G Cardboard box

Figure 1: Package content

The OBU contains all batteries and the power cable is designed for flexible installation. The Velcro tapes are already attached to the rear of the OBU. Remove the protective film for mounting the device on the windshield. Then the OBU can be mounted on the windshield.

In case the previous model of the OBU (C3080) was installed in the vehicle, the existing cable may be used. In that case the power cable included in the package will not be needed. For details go to “Exchange of the Yunex C3080 OBU for the Norbit VTP-1425 OBU” (Chapter 3.1.3).

The adapter is required for connecting the OBU to your vehicle’s power supply (depending on the socket).



Do not use the OBU if something is missing or damaged, and contact your Service Partner immediately.

# 03/



## Installation and mounting of the OBU

### 3.1 Installation of the OBU

There are two ways to install the OBU:

- 1 Fixed installation
- 2 Flexible installation

The main screen will show the status of the power supply as follows:

-  power supplied by connection to the vehicle's onboard system (recommended)
-  power supplied by the rechargeable battery. In the latter case the driver has to check the battery status during the trip when the OBU is not plugged into the cigarette lighter.



The OBU is designed for a voltage of 8 V - 32 V (DC) and must therefore be operated at voltages within this range. If the vehicle's onboard system can generate power with a higher voltage (e.g. starting aid by an external power source or by additional, more powerful generators in the vehicle), the OBU must be unplugged from the onboard system while the system operates at the higher voltage.

#### 3.1.1 Fixed installation

Connect the OBU permanently with the vehicle's power supply.

For fixed installation you must adhere to the wiring scheme shown below. Ensure that the circuit is protected by a fuse with appropriate rating.

Contact your Service Partner for more information.

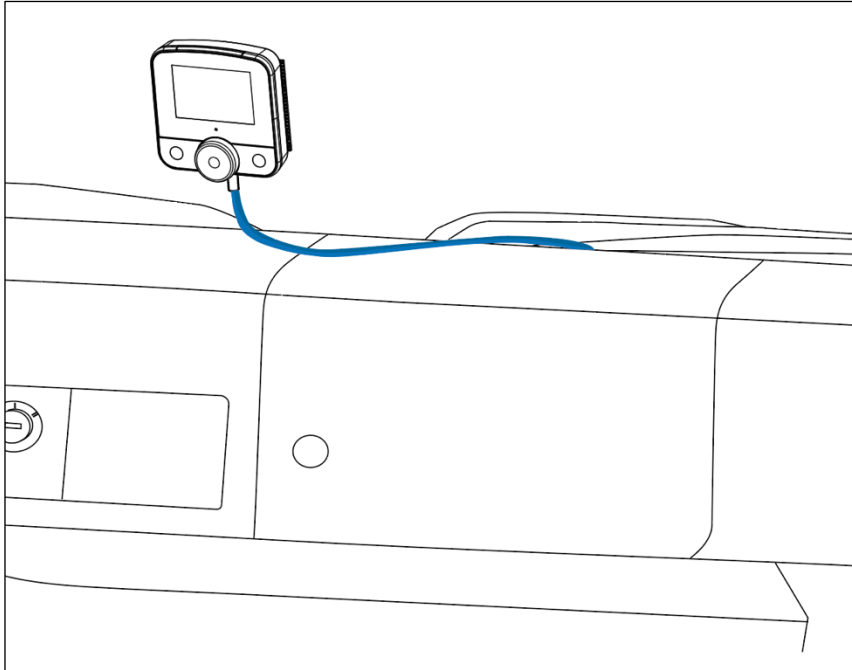

Figure 2: Fixed installation on the windshield



In ADR-vehicles only fixed installation is permitted and the installation must be performed by authorized staff. Contact your Service Partner in case you want the device to be installed in an ADR-vehicle

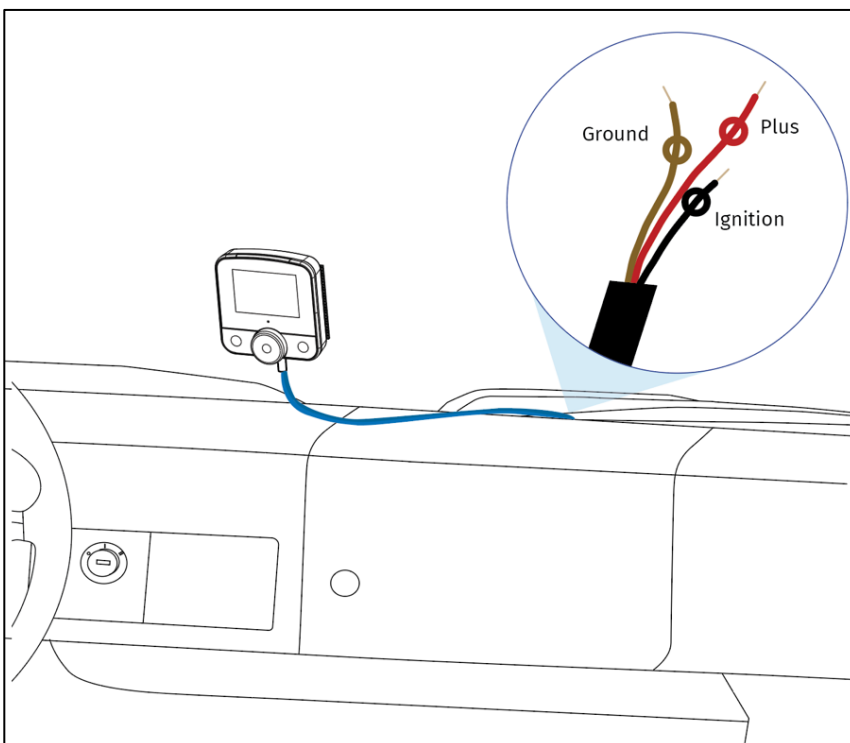

Figure 3: Wiring scheme for fixed installation

Vehicle onboard power supply:

**Red:** constant voltage (+)

**Black:** Ignition

**Brown:** Ground (-)

### 3.1.2 Flexible installation

Connect the OBU with the vehicle's cigarette lighter.

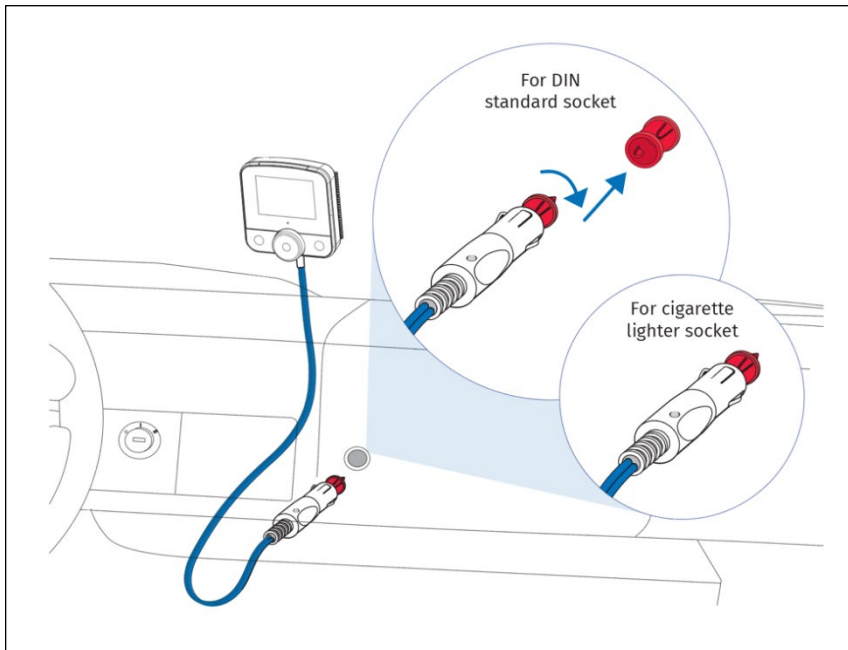



Figure 4: Flexible installation on the windshield

Mount the power cable in such a way that it cannot get disconnected while you are driving and does not impair the operation of the vehicle. If necessary, use the adapter for connecting the OBU to the power supply in your vehicle (depending on the socket).

-  The display will show the battery status.
-  The OBU will sound an alarm when the battery has reached a critical discharge status.



When the ignition switch is on/while the engine is running, the rechargeable battery is charged. When power for the OBU is supplied by the battery only (no connection with the cigarette lighter), it can be operated for up to four hours.



Check the battery status during the trip.



When the battery's charge drops below 25 %, the OBU will sound an alarm and show a warning on the display. The user can get back to the main screen only by confirming that they have read the message (by a click with the navigation key on the right hand side). Connect the OBU with a power supply as soon as possible.



### 3.1.3 Exchange of the Yunex C3080 OBU for the Norbit VTP-1425 OBU

Perform the following steps for exchanging the OBUs.

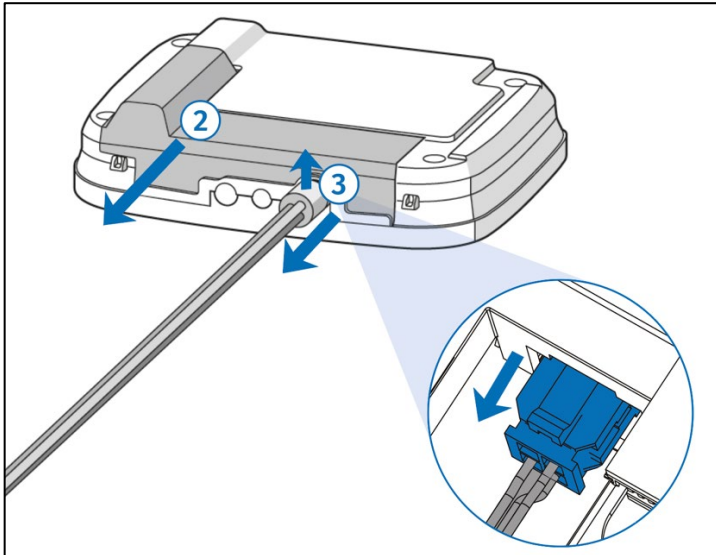

Figure 5: Exchange of the Yunex OBU for the Norbit OBU

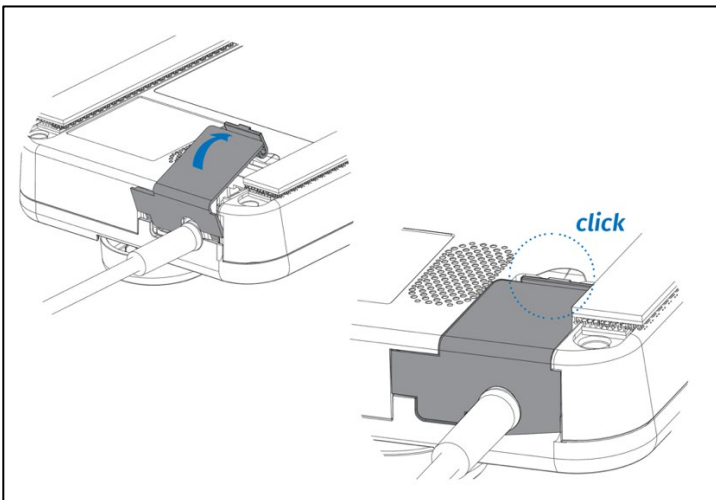

Figure 6: OBU cable cover

- 1 Remove the YUNEX C3080 OBU from the holder and remove the holder from the windshield.
- 2 Open the cable cover of the YUNEX C3080 OBU.
- 3 Lift the cable slightly and pull out the plug very carefully (WARNING: Do not pull on the cable!).
- 4 Take the Norbit VTP-1425 out of its packaging.
- 5 Push the plug into the Norbit VTP-1425 OBU and close the cover.
- 6 Mount the Norbit VTP-1425 OBU on the windshield as described in Chapter 3.2.

## 3.2 Mounting the OBU on the windshield

Mount the OBU on the windshield in such a way that

- it does not impair the driver's view while driving;
- the position is not close to moving parts (e.g. airbag covers);

- the OBU is visible from outside and is not covered by other parts (e.g. windshield wipers);
- the OBU does not impair the functioning of the air outlets;
- on metallized windshields the non-metallized area is used;
- national laws and regulations as well as recommendations of the vehicle manufacturer are taken into account.



Take into account the properties of the windshield, e.g. metallized/non-metallized areas, depending on the type of windshield used in your vehicle. Look for information on the windshield properties in your vehicle documentation. Windshield coatings may hinder the OBU to pick up GPS or GPRS signals.

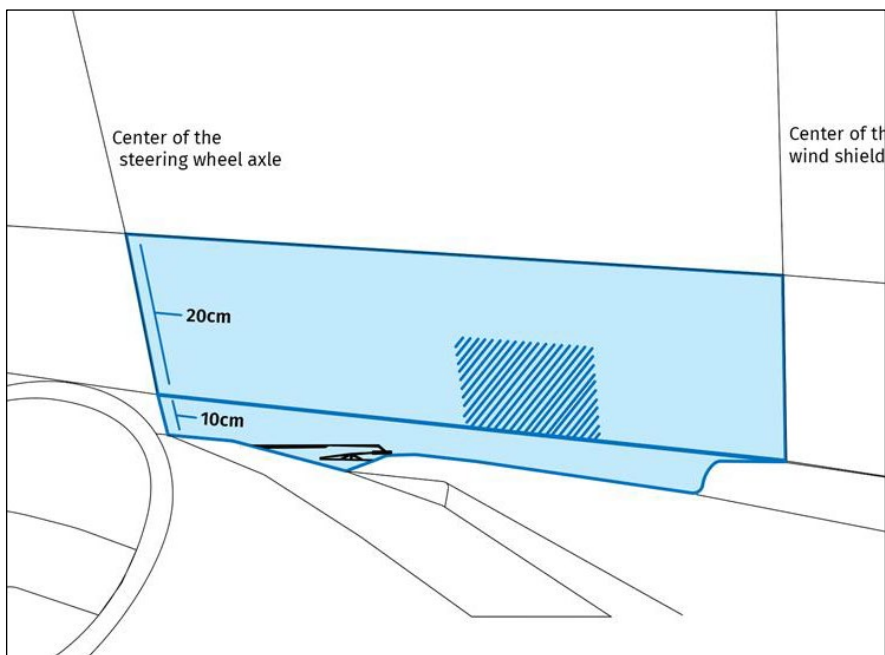

Figure 7: Correct placement of the OBU on the windshield



Ensure that the OBU is mounted in a place where it does not impair the driver's view.

### 3.3 Mounting the OBU on the windshield



When mounting the OBU on the windshield, ambient temperature must be above 20 °C. If necessary, heat the windshield to the respective temperature. The adhesive of the Velcro strips reaches its final strength 72 hours after the strips were attached provided that the temperature is 20 °C or more. To ensure that they bond firmly to the windshield you should press hard on the Velcro strips when placing them on the windshield.

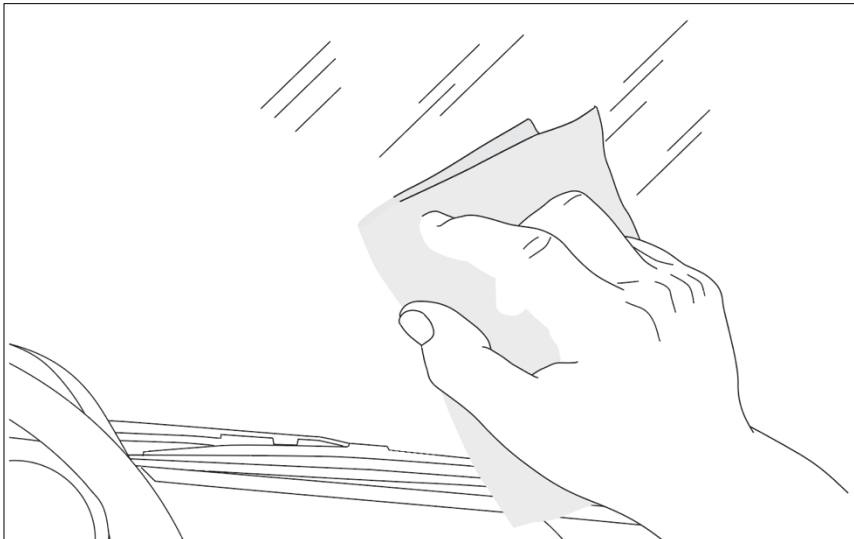

Clean the chosen area of the windshield carefully using the enclosed wipe. Wait until the surface is dry.

Figure 8: Windshield cleaning

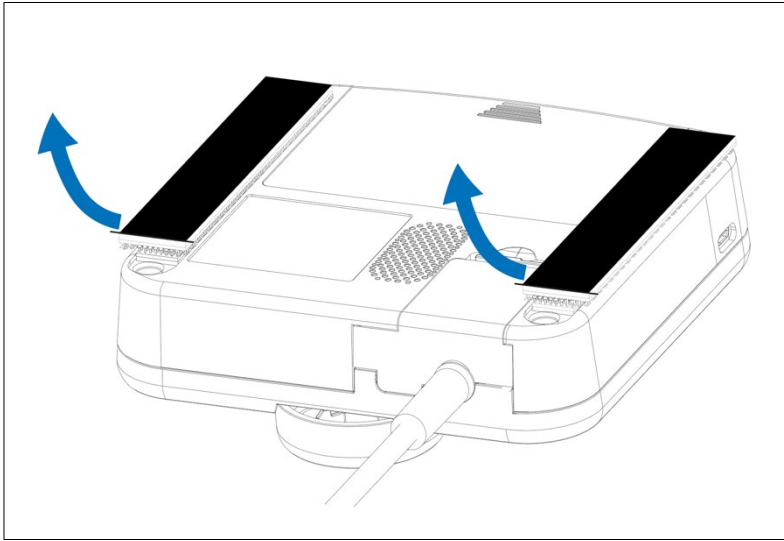

Figure 9: Removal of the protective film from the Velcro strips

Remove the protective film from the Velcro strips.

After that, orientate the OBU correctly (display on the top, navigation wheel and keys at the bottom) and press the rear of the OBU with the Velcro strips firmly onto the windshield.

# 04/

## Quick start

The figure below shows the controls:

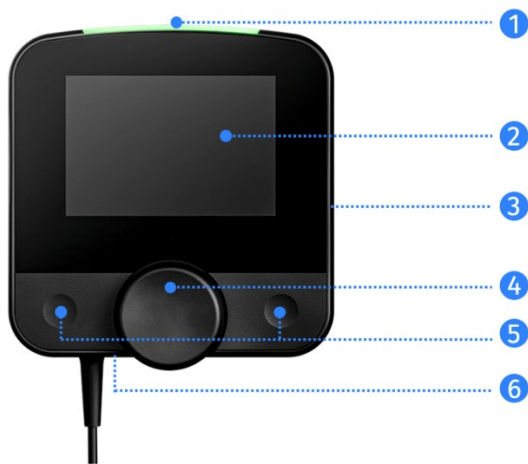

- 1 Status indicator (LED)
- 2 Display
- 3 Loudspeaker
- 4 Navigation wheel
- 5 Navigation keys
- 6 Socket for power supply

Figure 10: OBU controls

### 4.1 Requirements while driving

The OBU must be mounted on the windshield by means of the Velcro strips. The OBU must be visible from outside and it must not be covered.

It should not be positioned close to other devices (e.g. other OBUs/GPS trackers/airbags).

- Ensure that the OBU is supplied with power at all times.
- Do not handle the OBU or make settings on it while driving.
- Adhere to the traffic regulations.

For optimum recognition of the OBU in toll lanes (DSRC)

- Keep a distance of 4 m from the vehicle in front.
- Obey the signs in the toll lane.
- Pass the toll station only when the traffic light shows green.

## 4.2 First use of the OBU

The OBU is prepared for immediate use. Connect the OBU with the power supply and start your vehicle. The OBU will start booting as soon as it is supplied with power.

The OBU will be personalized with the vehicle data which were provided when you registered with your Service Partner. The OBU will also save the data for the EETS Service you selected.

- 1 The OBU's status light will be **red** until it is fully booted.
- 2 It will be **yellow** while the vehicle data (license plate number, weight) and the booked services are loaded via the mobile network (personalization "over the air"). When the OBU receives no GPS signal, the status light will also be yellow.
- 3 Eventually it will be **green** when the toll service was booked and personalized for the toll domain where the OBU is located at that moment. Now your OBU is ready for use.



Ensure that the OBU has a sufficiently strong signal (network for mobile communication) during personalization.



Ensure that the truck is not inside a building and that nothing blocks the windshield from the sky. In case the OBU does not receive a GPS signal, you should move it by a few metres.

The OBU receives software updates "over the air".

Contact your Service Partner in case you cannot follow the instructions in the manual or if you have any problems. Ensure that you have the most recent version of the manual.



Before the first trip: check if the license plate number and all other registered vehicle parameters are correct.

## 4.3 Main screen

The main screen is shown when the vehicle is inside an activated toll service area. For example, if the vehicle is in Germany and the German toll service (abbreviated as **DEbag**) is activated, the main screen will look like this:

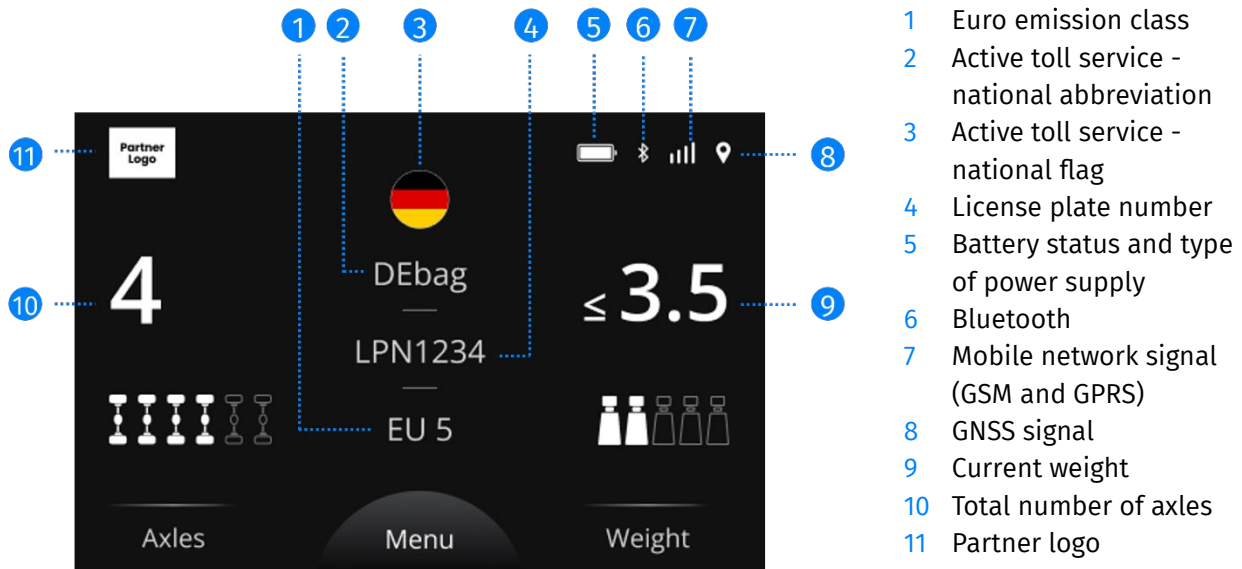

Figure 11: OBU main screen

When you are driving in an area where the OBU is activated, the display will always show the active toll service (2) with the respective national flag (3) and the license plate number (4). Weight (9)\*, number of axles (10) and Euro emission class (1) will be shown if this information is mandatory for the respective toll service and registered in the OBU database.

Symbols for the type of power supply (5), mobile signal reception (7) and the GNSS signal (8) will always be shown. In case you have activated Bluetooth, the Bluetooth symbol (6) will be shown. An active Bluetooth connection between the OBU and a mobile device will be indicated by a blue Bluetooth symbol.

The number of axles shown (on the static screen of the personalized OBU) is the total number of axles of the tractor as provided upon registration plus the number of trailer axles entered. The current number of axles is entered in the OBU by the driver (see Chapter 5.2).



For Germany and Poland the currently selected weight range is shown. For Switzerland this value indicates the calculated total train weight depending on whether a trailer is coupled to the tractor or not. For all other services the maximum permissible total train weight is shown if it is relevant for toll collection; in all other cases this place will be empty.

## 4.4 Status indicator

The status of the device is shown by means of a status indicator along the top edge of the device. In addition to that, a loudspeaker will issue an sound signal as warning or in emergencies.

The status indicator supports the user during the trip and reports responses of the device during various actions/situations.

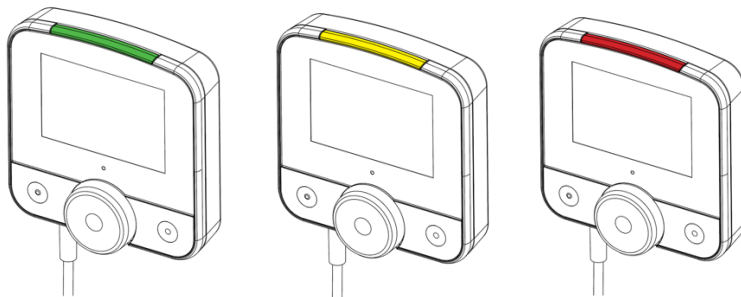

Figure 12: Status indicator

### Green

The OBU is active and ready for use. The toll is correctly charged for the current location. You can drive.

### Yellow

Check the message on the OBU display if the status indicator is yellow. The OBU is either:

- not yet personalized or
- the toll service is not activated for the area where the vehicle is located at that moment or it is not available on the OBU or
- there is no electronic toll system.

Please check which toll services are activated. In case you are liable to pay toll, use the toll device of the local toll operator.

### Red

In case the status indicator is red, a critical problem exists and the OBU does not collect toll. Stop and contact your Service Partner.

If you do not receive a GPS signal for obvious reasons (after 30 minutes without GPS reception the status indicator turns red), e.g. while you are in a tunnel or in a garage, drive to a place with GPS reception. When the status indicator shows red, its default setting is to flash.

### OFF

The OBU is not active. The OBU is off or in sleep mode (it will wake up when you switch on power or start moving).

## 4.5 Menu navigation

After the OBU has completed booting the start screen appears.

### Go to the main menu:

For accessing the main menu press the centre of the navigation wheel.



Toll4Europe 4G On-Board Unit  
Version 1.0 | GM 4.9



**Loudspeaker:**  
Signal for executed actions or warnings (e.g. when there is no GPS reception); confirmation for user actions (e.g. menu changes); indication of additional information while driving.

Figure 13: Navigation in the menu

- 1 Navigation wheel: Scroll down by turning the wheel clockwise. Scroll up by turning the wheel anticlockwise.
- 2 Navigation key on the left: Takes you back to the previous level/Cancel
- 3 Navigation key on the right: Takes you to the next level/Saves the selected entry.

## 4.6 Language selection

The OBU is available with 23 languages. For selecting the language, perform the following actions:

- 1 Press the centre of the navigation wheel to access the main menu.
- 2 Move the navigation wheel until you reach the point “Language” and confirm the selection by pressing the right hand side key.
- 3 Select the language you want by turning the navigation wheel and confirm the selection by pressing the centre of the navigation wheel or the right hand side key.
- 4 The OBU briefly shows the change of language and issues a sound signal for confirmation. You are then taken back to the main screen automatically.

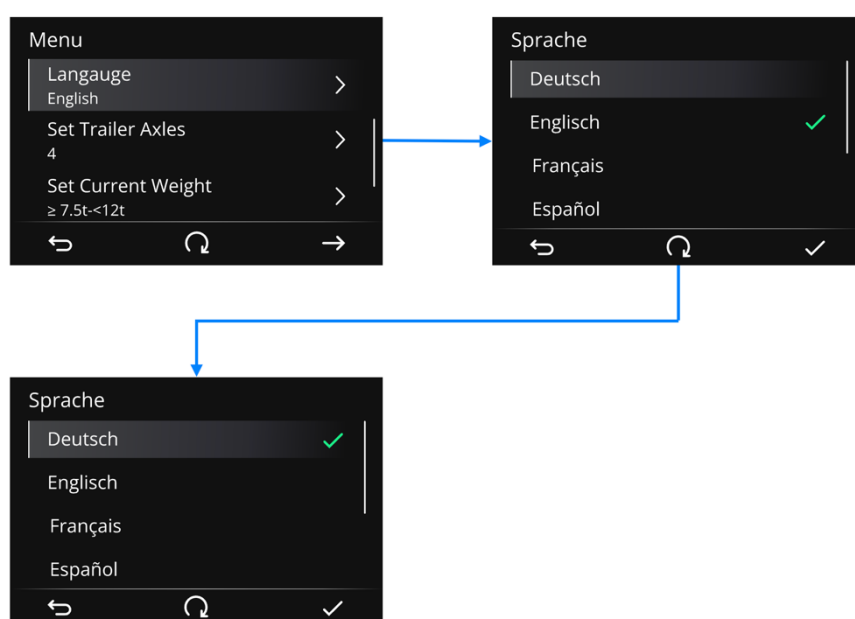

Figure 14: Language selection

# 05/

## Configuration

You can use the EETS Service only if certain vehicle parameters are transmitted. They are the basis for vehicle identification and calculating the toll fee. These data include, for example, the license plate number, the permissible total weight and the emission class.

Initial customer registration is performed by the Service Partner. The necessary data are transmitted to the OBU automatically during its personalization.

In some cases OBU parameters that are specific for a toll domain have to be updated by the driver during the trip. This is explained below.









### 5.1 Changeable OBU parameters

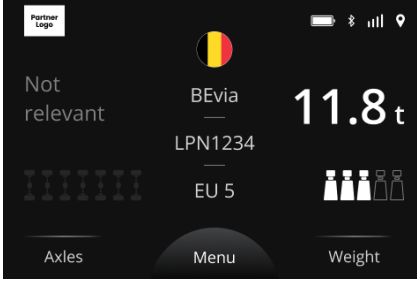

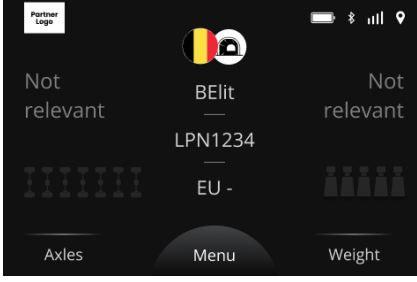

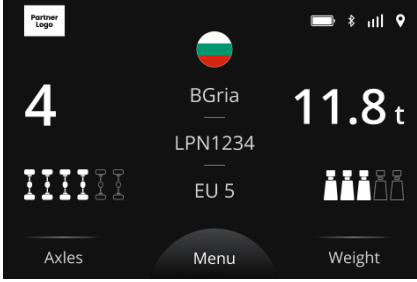

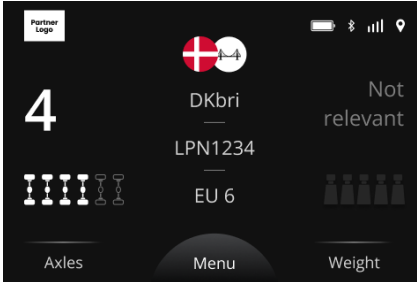

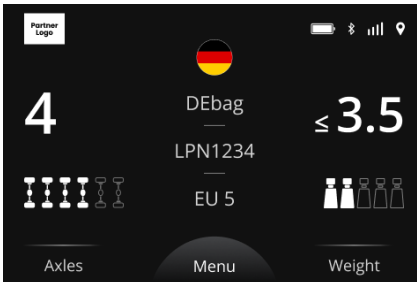
Because Toll Chargers require specific data for their toll domains, certain data have to be entered or updated in the OBU. This may result in different information appearing on the OBU display. Depending upon the regulations valid in a toll domain the number of axles and the permissible total train weight may have to be entered by the driver for the vehicle train at a particular moment. The driver is liable for the correctness and truthfulness of this information within the framework of the duty to self-declaration.

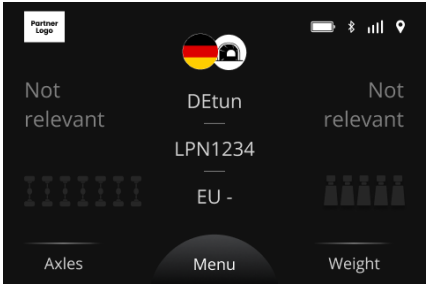

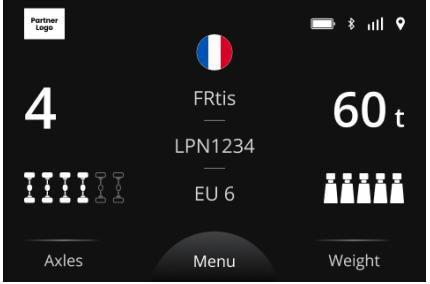

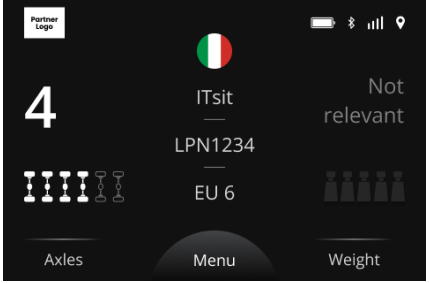

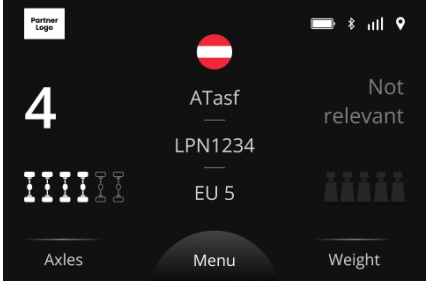

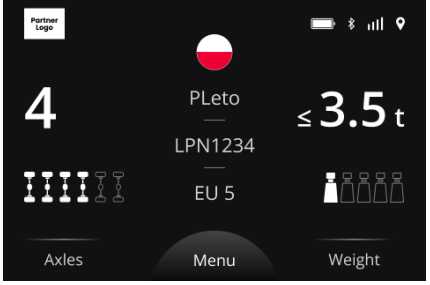
The table below shows which data have to be provided in which toll domain and what the main screen will look like for the individual toll services:

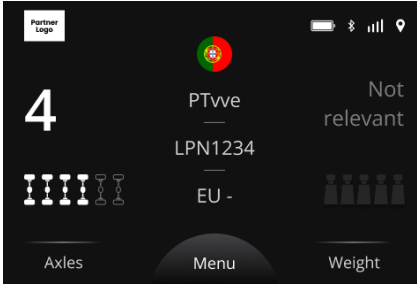

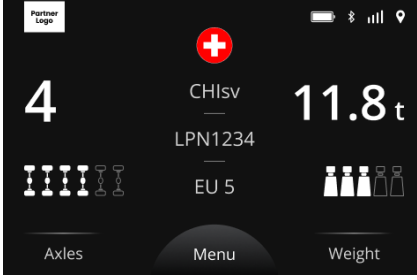
The driver is obliged to check conformity between the data entered in the OBU and the actual vehicle configuration. After coupling or uncoupling a trailer the driver always must adjust the number of trailer axles in the OBU.

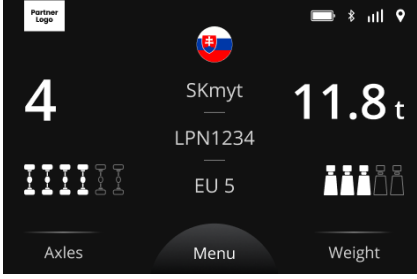
Toll service	Explanation	Parameter	Main screen
 BEvia: Belgium	<p>No special entry by the driver required.</p> <p>For Belgium the maximum permissible total weight of the vehicle combination according to the vehicle registration document is entered in the system already upon registration of the customer and will then be shown on the OBU screen automatically (in this case 11.8 t).</p>	-	
 BELit: Belgian tunnel - Liefkenshoek	<p>No special entry by the driver required.</p>	-	
 BGria: Bulgaria	<p>The <b>number of trailer axles must</b> be updated when a trailer is coupled to or uncoupled from the tractor.</p> <p>For Bulgaria the maximum permissible total weight of the vehicle combination according to the vehicle registration document is entered in the system already upon registration of the customer and it will then be shown on the OBU screen automatically (in this case 11.8 t).</p>	Number of axles	
 DKbri: Storebælt bridge and Øresund bridge	<p>No special entry by the driver required.</p>	-	
 DEbag: Germany	<p><b>Axles:</b> The current total number of axles for the vehicle combination is shown. It may vary depending on the trailer used. For this reason the driver has to enter the number of trailer axles in the OBU.</p> <p><b>Weight:</b> After coupling or</p>	Number of axles Current permissible total weight of the vehicle train	

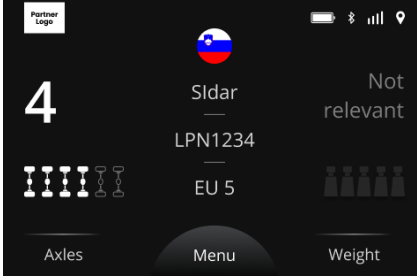
 <p>DEtun: German tunnels - Warnowquerung + Herrentunnel</p>	<p>uncoupling a trailer the new, actual permissible total weight of the vehicle train must be updated.</p> <p>No special entry by the driver required.</p>	-	
 <p>FRtis: France</p>	<p>The <b>number of trailer axles must</b> be updated when a trailer is coupled to or uncoupled from the tractor.</p> <p>The number of axles is additionally determined by the toll operator's roadside installations.</p>	Number of axles	
 <p>ITsit: Italy</p>	<p><b>Axes:</b> The <b>number of trailer axles must be updated</b> when a trailer is coupled to or uncoupled from the tractor.</p>	Number of axles	
 <p>ATasf: Austria</p>	<p>The OBU shows the total number of axles of tractor plus trailer.</p> <p>The <b>number of trailer axles must</b> be updated when a trailer is coupled to or uncoupled from the tractor.</p>	Number of axles	
 <p>PLeto: Poland</p>	<p><b>Weight:</b> After coupling or uncoupling a trailer the new, actual permissible total weight of the vehicle train must be updated.</p> <p>For PLeto the driver has to enter the current total weight of the vehicle train before entering Poland.</p>	Current permissible total weight of the vehicle train	

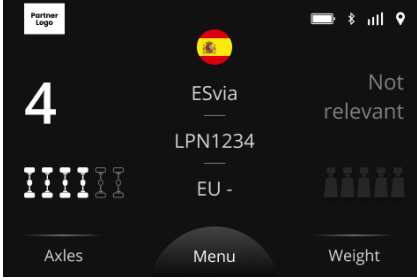
 <p>PTwe: Portugal</p>	<p>The <b>number of trailer axles</b> should be updated when a trailer is coupled to or uncoupled from the tractor.</p> <p>The number of axles is additionally determined by the toll operator's roadside installations.</p>	<p>Number of axles</p>	
 <p>CHIsv: Switzerland</p>	<p><b>Axles:</b> The current total number of axles for the vehicle combination is shown (here: "3"); it may vary depending on the trailer used. For this reason the driver has to enter the number of trailer axles in the OBU.</p> <p><b>Weight:</b> After coupling or uncoupling a trailer the new, actual permissible total weight of the trailer must be declared. The main screen shows the total weight. For more information, see chapter 9.12.</p>	<p>Number of axles; permissible maximum trailer weight</p>	
 <p>SKmyt: Slovakia</p>	<p>The <b>number of trailer axles</b> must be updated after coupling or uncoupling a trailer.</p> <p>The number of axles is additionally determined by the roadside equipment of the Toll Chargers.</p>	<p>Number of axles</p>	
 <p>Sldar: Slovenia</p>	<p>The OBU shows the total number of axles of tractor plus trailer.</p> <p>The <b>number of trailer axles must</b> be updated when a trailer is coupled to or uncoupled from the tractor.</p>	<p>Number of axles</p>	
 <p>ESvia: Spain</p>	<p>The <b>number of trailer axles</b> should be updated when a trailer is coupled to or uncoupled from the tractor.</p> <p>The number of axles is additionally determined by the toll operator's roadside installations.</p>	<p>Number of axles</p>	

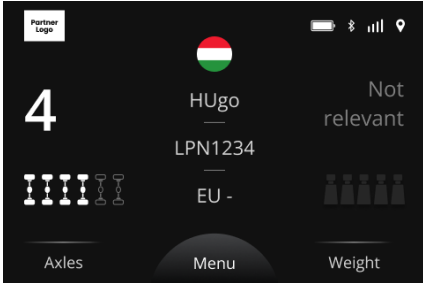
 HUgo: Hungary	The OBU shows the total number of axles of tractor plus trailer. The <b>number of trailer axles must be updated</b> when a trailer is coupled to or uncoupled from the tractor.	Number of axles	
---	---	-----------------	---

## 5.2 Trailer axles

When entering a toll domain, the driver always has to check or change the number of axles, in particular after coupling or uncoupling a trailer.

Example for changing the number of trailer axles:

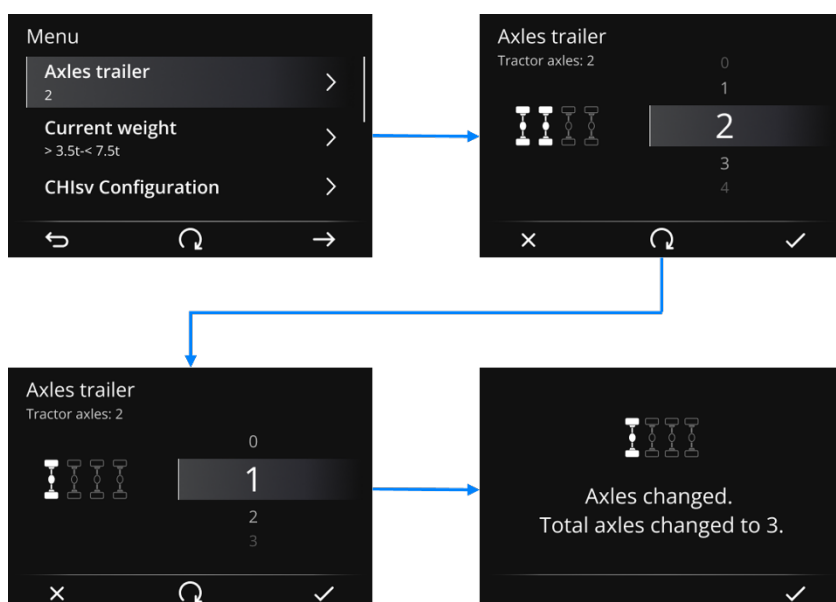

Figure 15: Changing the number of axles

The number of axles can be changed in the menu under **“Axles”**. For changing the number, turn the navigation wheel until the required value appears. Confirm the entry by pressing the navigation key on the right hand side. The OBU will show you the changed number of axles briefly for confirmation before it goes back to the main screen automatically.

You can also use this menu for checking which number of axles is entered at a particular moment. If you do not want to change the number, leave the menu by pressing navigation key at the bottom left. If you set a new number of axles but did not save it,

the OBU will show the message “Value not changed” for a few seconds and the old value will be kept.

### 5.3 Current weight

For Germany (DEbag) the user has to check the value of the currently permissible total weight of the vehicle train (tractor + currently coupled trailer) and update it (if applicable) before entering Germany, in particular, if the trailer was changed. The current total weight of the vehicle train is the combination of the permissible maximum weight (F.1) of the tractor and the permissible maximum weight (F.1) of the trailer coupled with it at that particular moment.

For Poland (PLeto) the currently permissible total weight of the vehicle train (tractor + currently coupled trailer) must be set by the driver before entering Poland.

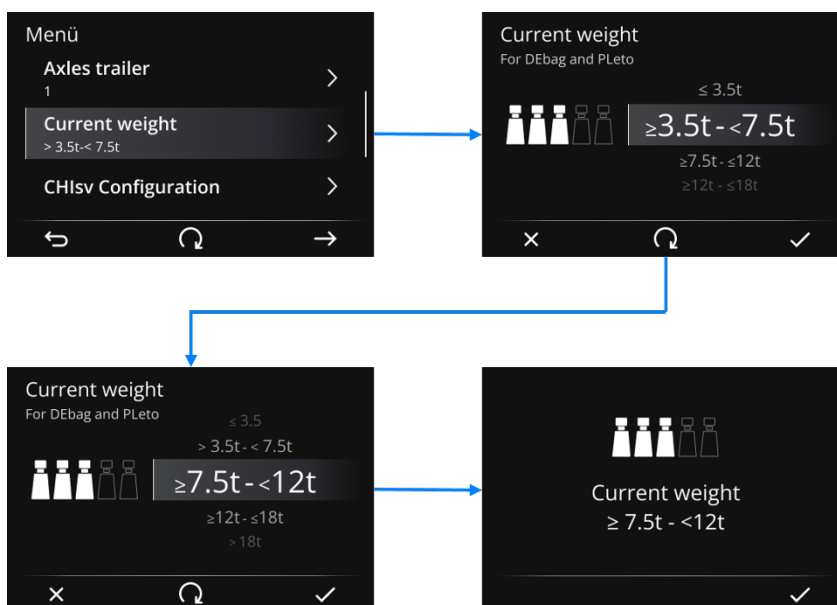

Figure 16: Change of weight

Press the bottom right navigation key after updating the value by means of the navigation wheel to confirm the entry. The OBU will show you the changed weight briefly for confirmation before it goes back to the main screen automatically.

You can also use this menu for checking which weight is entered at a particular moment. If you do not want to change the value, leave the menu without saving by pressing the navigation key at the bottom left. If you set a new weight but did not save it, the

OBU will show the message “Value not changed” for a few seconds and the old value will be kept.

## 5.4 Configuration for Switzerland CHIsv

### 5.4.1 Entering the trailer weight

For Switzerland (CHIsv) the user always has to check and/or update the configuration of the trailer weight before entering the country, **in particular if a trailer was coupled or uncoupled**. The current gross trailer weight is the maximum permissible weight of the attached trailer according to the vehicle registration document. The weight must be rounded down to the nearest 10 kg.

When personalizing the Swiss service on the OBU, the expected gross trailer weight is configured on the OBU. When you use a trailer with a different weight, you have to adjust the setting for the trailer weight.

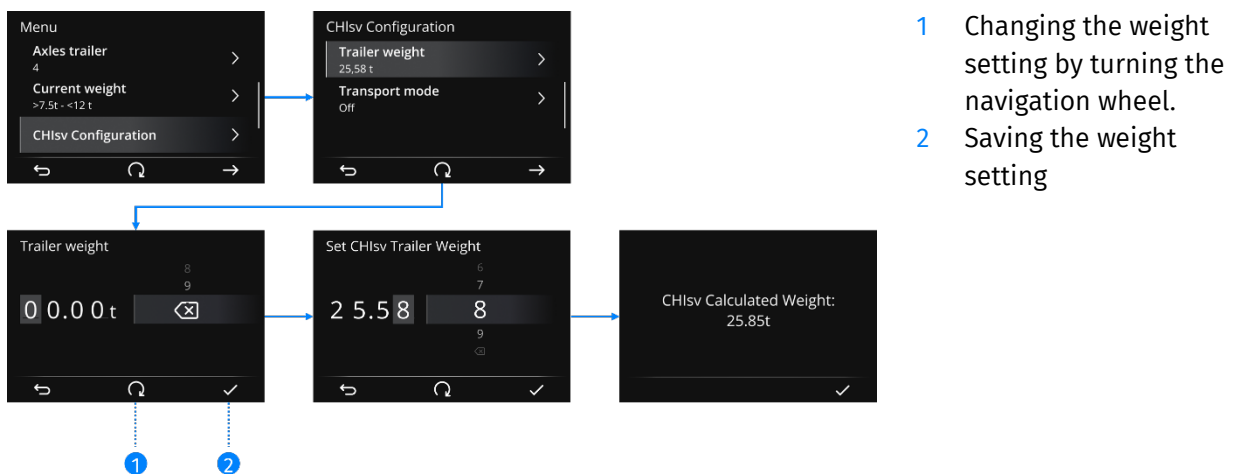

Figure 17: Configuration for CHIsv

The weight setting can be changed in the menu under „[Configuration CHIsv](#)“ and then "[Trailer weight](#)". In the default setting, all digits are set to zero. The digit highlighted with the grey cursor can be changed; the cursor moves from left to right. The number is changed by moving the navigation wheel. Clicking in the centre of the navigation wheel or the right navigation button confirms the number and the cursor moves one position further.

Press the bottom right key for “OK” when you have finished updating the value. The OBU will show you the changed weight

briefly for confirmation before it goes back to the main screen automatically.

The trailer weight is relevant only if a trailer is used (trailer axles > 0). It does not need to be set to zero if no trailer is used (the driver cannot enter the value zero as permissible weight).

You can also use this menu for checking which weight is entered at a particular moment. If you do not want to change the weight, leave the menu without saving by pressing the bottom left navigation key for “Return”. If you set a new weight but did not save it, the OBU will show the message “Value not changed” for a few seconds and the old value will be kept.

## 5.4.2 Transport mode

If the vehicle is not self-propelled (e.g. if it is carried by a train), the road user has to activate transport mode. This is relevant only for trips in Switzerland. For activating transport mode go to “Configuration CHIsv” in the menu.

For activating transport mode select “Transport mode on” and press the bottom right key for “OK”. This activates transport mode.

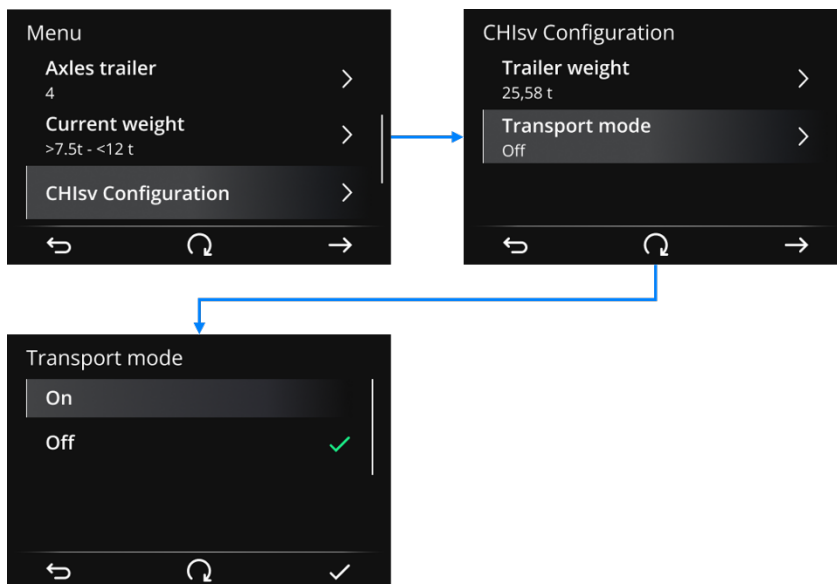

Figure 18: Activating the transport mode

During trips with activated transport mode the OBU’s status indicator is **red** and the display shows the below indication.

Distances covered in transport mode are not used for calculating toll.

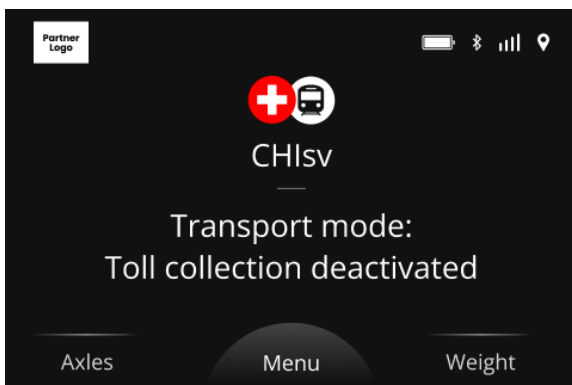

Figure 19: Activated transport mode

Transport mode can be activated before entering Switzerland. If that is done, the OBU will change into transport mode automatically when crossing the border to Switzerland. Transport mode will be active until it is deactivated or until the OBU crosses the Swiss border and leaves Switzerland.

# 06/

## Driver information and additional functions of the OBU

### 6.1 Booked toll services

The OBU shows all toll services booked. The name of a service will not be shown if the OBU was not personalized for that toll domain. You can book or activate/deactivate additional toll services through your Service Partner at any time. Booking and activating toll services before starting a trip is essential.

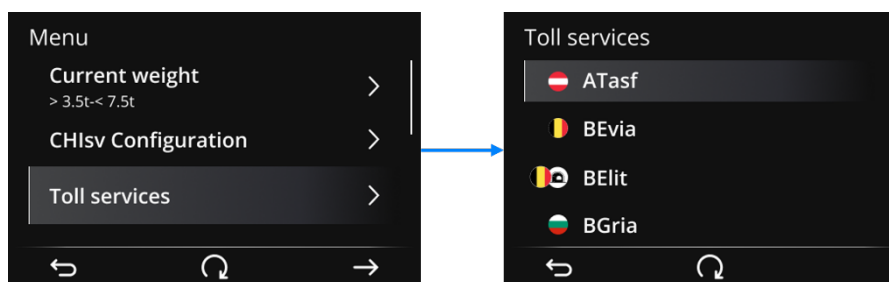

Figure 20: Toll services

### 6.2 Vehicle parameters

All vehicle parameters can be found in the list below.

Information on particle filters is shown with a choice of Yes/No. “Yes” means that the particle filter shown is relevant for toll collection. “No” is shown if the registered particle filter does not have an impact on toll calculation.

The CoP value represents „CO2 in g/km”. Personalizing it is optional for Austria and Italy. The attribute is filled with “0” if the customer did not enter a value for this parameter.



The values for emission class, number of tractor axles and particle filter are not entered by the driver. These values are entered once by the Service Partner. They cannot be changed on the OBU.

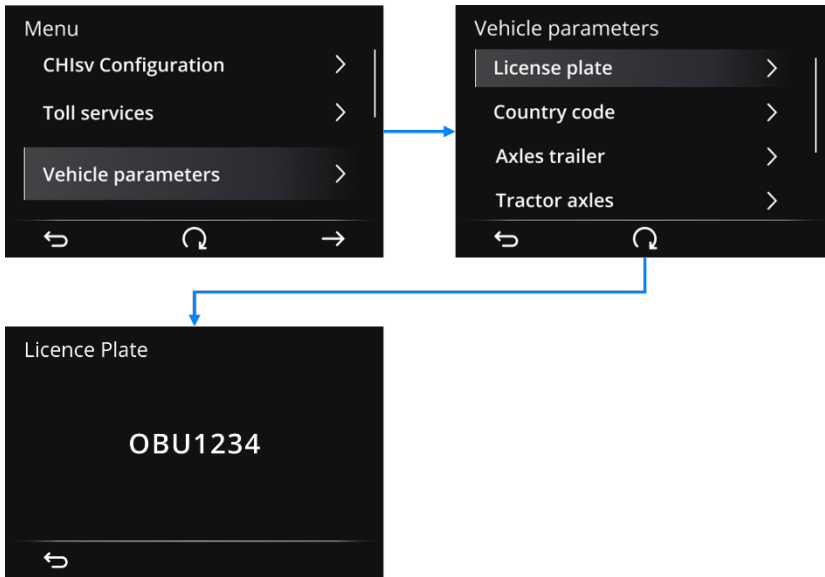

Figure 21: Vehicle parameters

## 6.3 Additional services

If you go to this menu entry, all activated additional services will be shown.

# 07/

## Driving with the OBU

### 7.1 Starting the engine

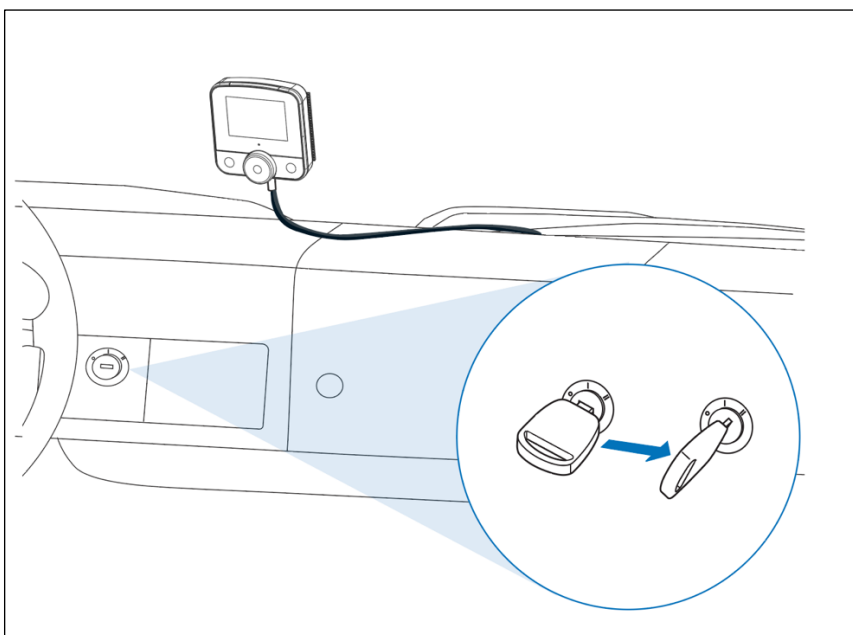

Figure 22: Starting the OBU

- The OBU boots automatically when you turn on the ignition (fixed installation) or it responds to motion or when a key is pressed (flexible installation). The booting information is shown on the display. The main screen shows the status of the OBU.
- The OBU performs basic configuration and activation automatically. The vehicle data for the respective OBU are provided in accordance with the registration data supplied by your Service Partner.
- Please note that the OBU shows the EETS Service available at your current location.

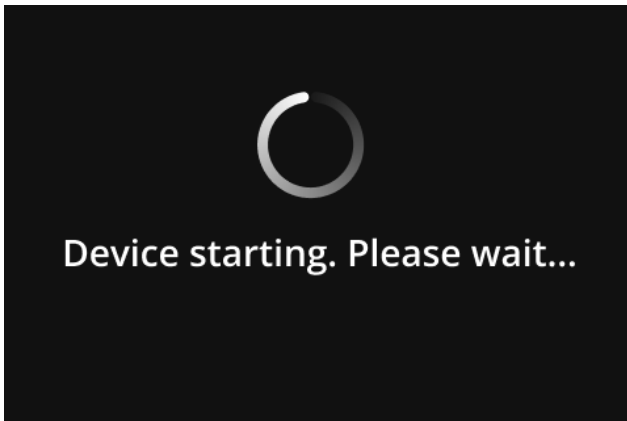

Figure 23: Device boots

The device boots and loads all OBU and vehicle data. Usually this takes only a few minutes.

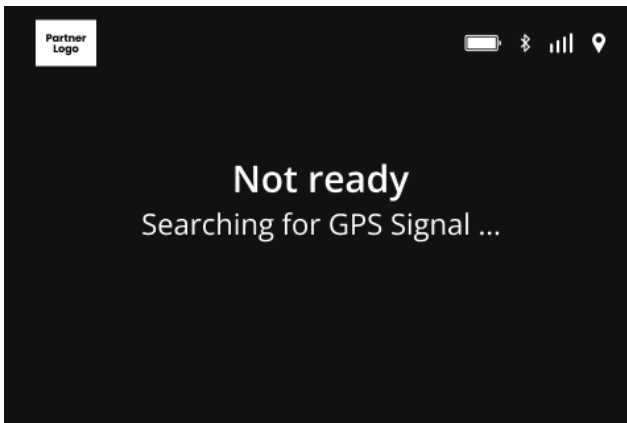

Figure 24: Not ready

The T4E-OBU is not yet ready and searches for a GPS signal.

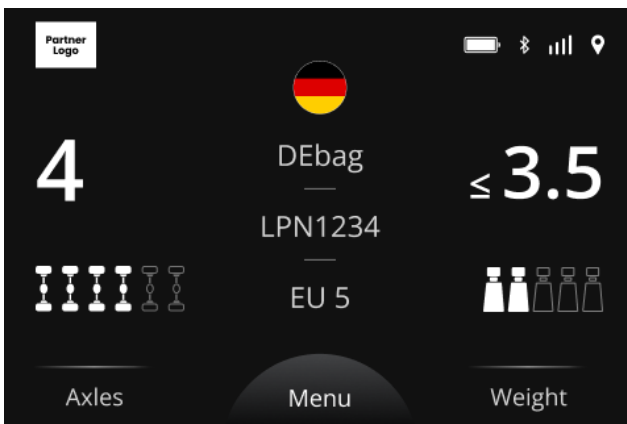

Figure 25: Ready

The EETS Service is detected and shown with the respective indications on the main screen. The T4E-OBU is ready. You can start your trip.



Before beginning your trip:

Check the vehicle data (license plate number, number of axles) and the settings for the EETS Service.

Change the settings when necessary (see Chapter 5.1 OBU parameter settings):

- number of axles
- permissible total weight of the vehicle train

More information regarding the display indications is given in Chapter 8.1. In case you intend to change settings of the OBU (e.g. the language), Chapter 10.2 has information on how to do it.

## 7.2 Modes of operation

### Standard:

When the vehicle is moving, the OBU is in the “Standard” mode of operation. All data are available and the OBU is ready. When the OBU detects that the vehicle is in motion, it is ready to count the kilometres driven. The main screen shows the state and the system informs the driver on changes of the operating mode and changes related to the location.

### Sleep

Flexible installation: If the OBU does not detect any motion for a duration of 30 minutes, it will change into sleep mode. When the vehicle is set in motion, the OBU will change to standard state within few seconds.

Fixed installation: The OBU changes into sleep mode if the ignition is off for more than 30 minutes. When the ignition is turned on, the OBU will change to standard state within few seconds.

### Operating mode “Power saving”

Flexible installation: The OBU changes into power saving mode as soon as the power cable is plugged out of the cigarette lighter socket. The display lighting is reduced. The T4E OBU remains ready for operation. Check the battery status during the trip.

Fixed installation: After the ignition is turned off, the OBU changes into power saving mode. The display lighting is reduced.

## Transport mode/OBU off

The OBU is in transport mode when it is sent to the costumers. Connecting it with a power supply activates it.

When the OBU is not supplied with power and the battery charge drops below a certain limit, the OBU switches off automatically. Also in this case the OBU will wake up only if it is supplied with power.

## 7.3 Indication of information on the OBU

Depending on the location of the vehicle the OBU shows all relevant information during a trip. It detects registration with the respective EETS Service and the parameters that are applicable for the EETS domain.

### Display of information while moving within a booked EETS Service

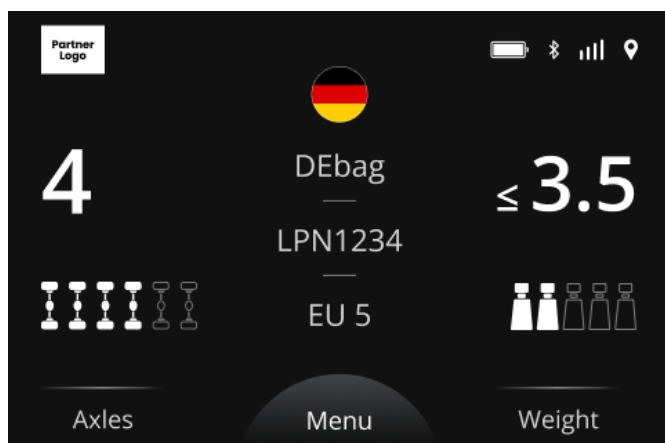

Figure 26: Main screen

You can put the vehicle in motion after checking and/or entering the respective vehicle parameters. You are moving in the domain of a booked service where the vehicle parameter "Number of axles" is not subject to toll. You can continue your trip.



The OBU issues a sound.  
In some toll domains the national Toll Chargers requires that a sound signal alerts the driver after a toll bridge was passed and a transaction was executed. You can continue your trip.

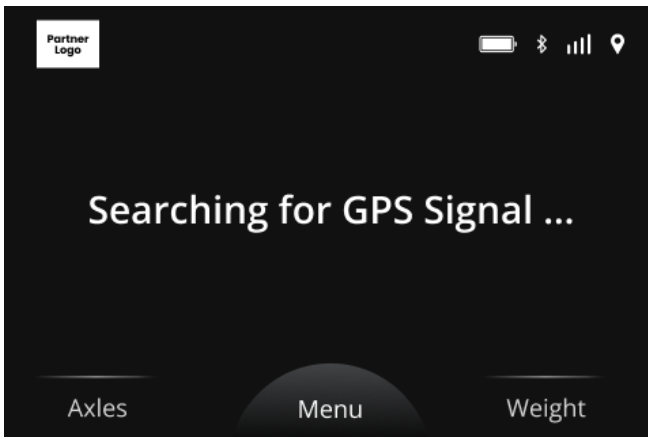

Figure 27: Searching for GPS signal

This message is shown when the OBU does not detect a GPS signal. If it does not detect a GPS signal for more than 30 minutes, the LED turns red and the display shows the message “Not ready”.

### Display of information while moving outside booked services

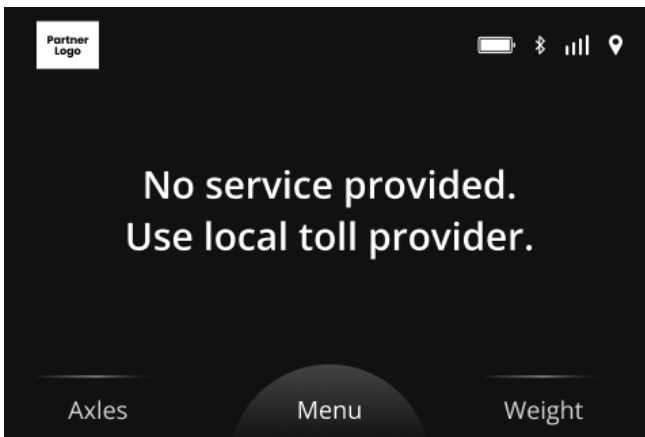

Figure 28: No service available

You are driving in an area where no service has been booked. The OBU is out of operation in this toll domain and toll is not collected by the OBU. Please check if you have to use the device of a different provider or an alternative payment method for this domain.

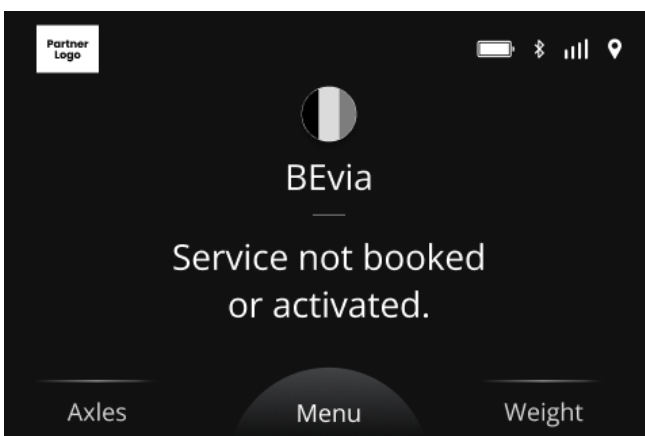

Figure 29: Service not booked or activated

Message shown while driving within range of a known but not booked EETS-Service: You are moving in a toll domain where the T4E toll service was not booked or the booking process was not completed. Check whether the service should be booked through your Service Partner.

## Special OBU messages while driving in Switzerland

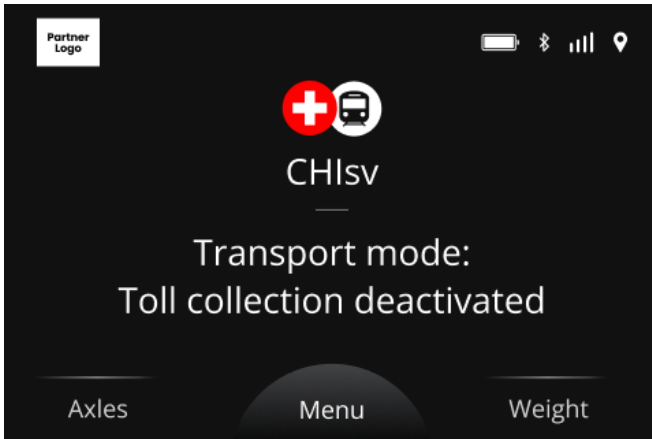

Figure 30: Transport mode

The vehicle is not self-propelled (e.g. the vehicle is carried by a train). The OBU does not collect toll fees. Kilometres covered while the vehicle is not self-propelled are not counted for fee calculation.

You find more information on warnings or for OBU problem solving in Chapter 8.1.

## 7.4 Toll lanes

### General information

When entering a road subject to toll the OBU must be mounted on the windshield. The driver must not handle the OBU while driving.

For optimum detection of the OBU in toll lanes the driver must

- ensure that his vehicle has a distance of at least 4 metres from the vehicle in front;
- pay attention to the toll lane signs and follow their instructions;
- pass the toll barrier only when the traffic light is green.



























When the OBU is properly detected, a signal can be heard, the light turns green, the barrier opens.

### Emergency procedure in case of disturbances/defects

The website of the Toll Charger shows a list of the accepted means of payment.

If necessary, the driver can press the emergency key and follow the instructions given by the Toll Charger staff.

Contact the Service Partner if the OBU is out of order.

 		 						<p><b>Roads subject to toll – recommended behaviour</b></p>
		 	 					<p>Please use the lanes indicated on these signs if you want the toll to be charged automatically through your OBU.</p>
							 All  Buses & Trucks	<p>Please use the lanes indicated on these signs if you want the toll to be charged automatically through your OBU and your vehicle belongs in category 4. In general we recommend to use the lane for “Buses and Trucks”.</p>
								<p>Please use the lanes with the sign “30” (speed) if you pass the station at a higher speed. Make sure that you keep a distance of at least 4 metres from the vehicle in front of yours and do not pass before the light is green.</p>
								<p>Please use the lanes with these signs if you want to use manual toll collection or if your OBU is out of order and you have to pay the toll in cash or by a card.</p>
								<p>Use the lanes with the green signs whenever possible. Customers with an OBU should use the GREEN lanes. You may also use the BLUE lanes. In this case the driver has to select “Payment with OBU” at the self-service kiosk.</p>

## 7.5 Examples for driving through various EETS domains

While driving through Europe the OBU will show if an EETS Service was booked (for the local toll service) or not (“No valid service”). Depending on the configured vehicle parameters (axles, weight) the OBU determines the amount of toll.

Below we show two examples for trips through European toll domains. You can see how the information shown on the display changes during the trip.



The driver has to enter the number of axles and the permissible maximum weight of the vehicle train depending on the currently used trailer and the EETS domain.

### Example:

EETS Services were booked for Belgium (BEvia), but not for Germany (DEbag). Vehicle parameters: The permissible total weight without trailer is 7.5 t. The vehicle is subject to toll in Belgium. No EETS Service was booked for Germany. Czechia is not included in EETS.

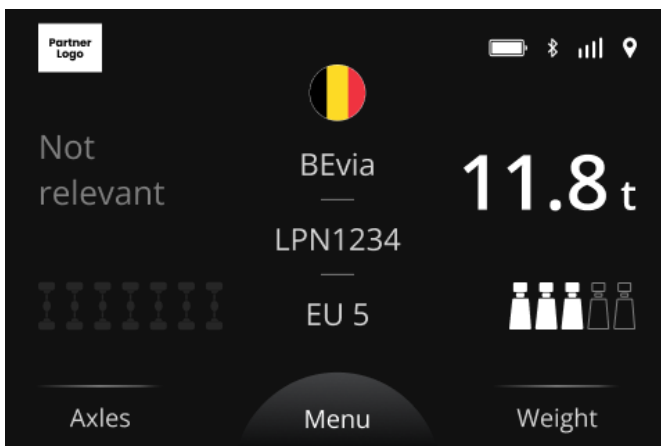

**Situation:** Driving in Belgium

**Explanation:** The main screen shows the active EETS Service and the related parameters.

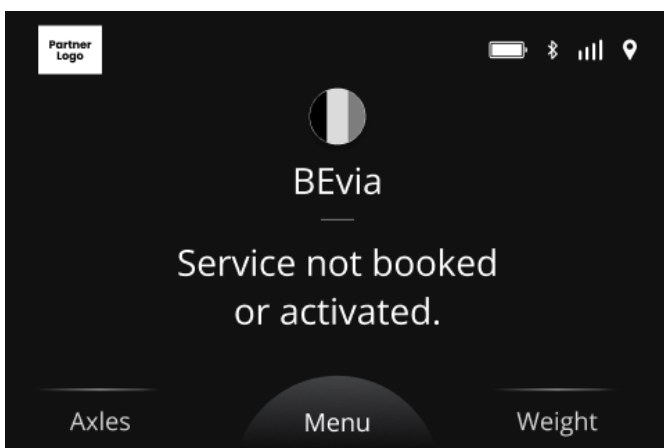

**Situation:** Crossing the border and driving in Germany

**Explanations:** After crossing the border to Germany the LED turns yellow since the Debag service was not booked. The vehicle is subject to toll in Germany. You may contact your Service Partner to book the EETS Service for your OBU or you use a device provided by the national toll operator.

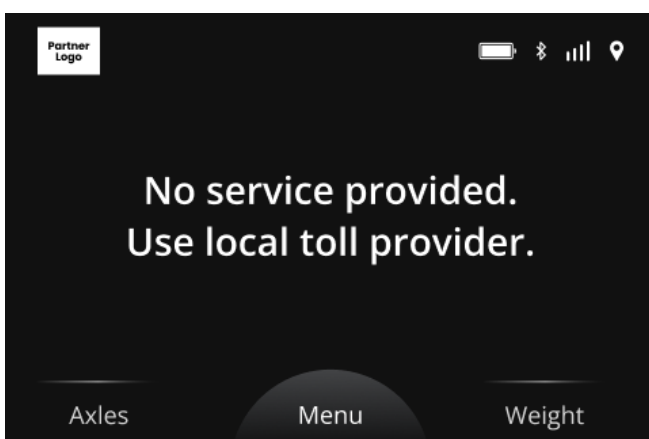







**Situation:** Crossing the border and driving in Czech Republic



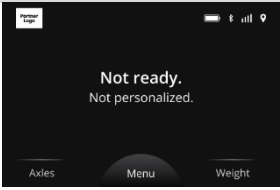

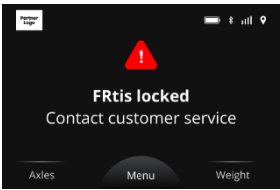
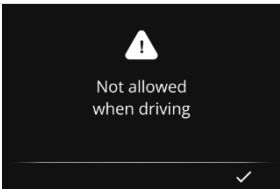

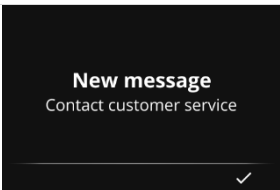

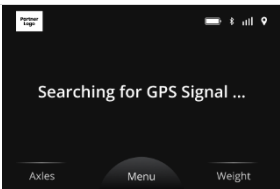

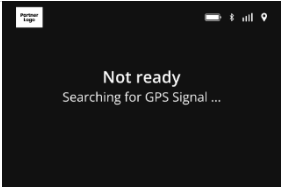

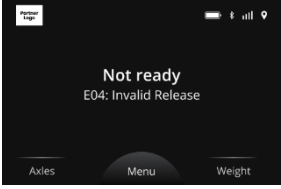
**Explanations:** You are driving in an area that is not known to the OBU and that cannot be booked therefore. Please check if you have to use the devices of another service provider for toll payment.

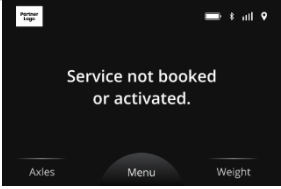
## 08/

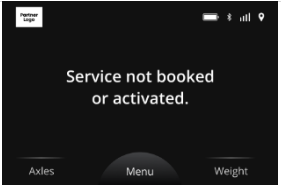
# Error management and emergency procedures

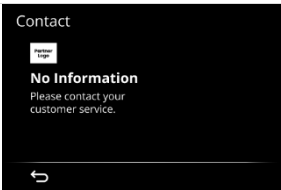

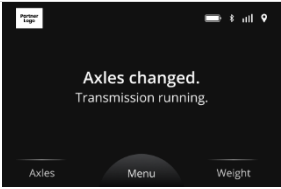

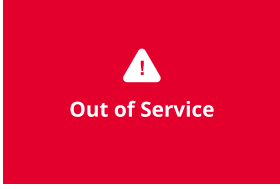
## 8.1 Error detection and trouble shooting

Status indicator	Main screen	Error detection and trouble shooting	Possible errors
		Please wait for a few minutes until your device is fully personalized and ready for operation.	The OBU is not fully personalized or not all data are available after a wireless update.
		Do not drive with this OBU showing a red status light; contact your Service Partner.	The OBU was blocked for the French toll system (FRTis).
unchanged		You must not try to open the menu while driving. The menu must not be open while driving.	Warning when the driver attempts to open the menu while driving, e.g. for changing a parameter.
		Please contact your Service Partner immediately after completing the trip.	Your OBU instructs you to contact the Service Partner after the trip.
		Please continue driving for a few minutes. GPS reception will probably improve, e.g. after leaving a tunnel. Leave the motorway or road subject to toll as soon as possible if GPS reception does	Depending on your location GPS reception may be poor (e.g. in a tunnel).

		not improve. After 30 minutes the LED turns red. Contact your Service Partner.	
		Leave the road subject to toll and contact your Service Partner.	If you have no GPS reception for more than 30 minutes, the LED turns red.
		Stop the vehicle. Normally the T4E OBU searches for software updates each time it boots and loads them down. Wait for a short while. In case you cannot wait longer or you waited a long time already, contact your Service Partner and follow the instructions given by their staff.	This error can occur if you have not used the OBU for a prolonged period of time. This message means that the OBU software is out of date and has to be updated.
		Contact your Service Partner to book the EETS Service on the OBU or use the device provided by the local toll provider.	You are driving in an area where T4E detects an EETS Service. However, this EETS Service is not activated on your OBU.
		Check whether your vehicle is subject to toll and if you have to pay toll via another provider before you continue the trip. If in doubt contact your Service Partner.	You are driving in an unknown domain without an EETS Service that your OBU recognizes.
		Here you find the telephone number of your Service Partner. Continue your trip.	
		Wait until data transmission is complete. Then you are taken to the main screen automatically.	If the OBU is located in Hungary and the transmission is not confirmed in time, the error message "Number of axles changed - transmission ongoing" will be shown.
		Leave the road subject to toll and contact your Service Partner.	The issue might be caused by hardware failure.

## 8.2 Alternative payment methods

If an malfunction persists at an entry or exit toll station, the driver has to use an alternative payment method eventually. The driver should always carry an alternative means of payment, e.g. a fuel card, credit card or cash (in France this is mandatory).

Toll Charger	Explanation	Link	Alternative payment methods			
						
<b>Belgium (VIAPASS)</b>	Get a local OBU issued by the national provider Satellic. Customers can acquire OBUs at one of the 120 sales points (Satellomates) at the border and in Belgium and return them upon leaving Belgium to collect the deposit. No extra cost is connected with this.	<a href="#">Link BE</a>	Yes	Yes	n/a	No
<b>Belgium Liefkenshoek Tunnel</b>	Use the local service provider for manual payment with cash or card.	<a href="#">Liefkenshoek</a>	Yes	Yes	No	No
<b>Bulgaria (RIA)</b>	Buy a ticket or a vignette online and at a point of sale (POS).	<a href="#">Link BG</a>	Yes	Yes (Debit/ Credit card)	Yes	Yes
<b>Germany (BALM)</b>	Book your trip at the Toll Collect web portal. You can do this up to 24 hours before starting the trip.	<a href="#">Link DE</a>	No	Yes	No	Yes
<b>German tunnels (Herren-tunnel and Warnow tunnel)</b>	Use the local service provider for manual payment with cash or card.	<a href="#">Warnowquerung</a> <a href="#">Herrentunnel</a>	Yes	Yes (Herren-tunnel only fleet cards)	No	No
<b>France (ASFA)</b>	Use the alternative lane for manual toll collection on the motorways. Use cash or card to pay toll.		Yes	Yes	Yes	No
<b>Italy (AISCAT)</b>	Use the alternative lane for manual toll collection on the motorways. Use cash or card to pay toll.		Yes	Yes	Yes	No
<b>Austria (ASFINAG)</b>	Get a local prepaid OBU (GO-Box) issued by ASFINAG. There are many sales points near roads subject to toll before crossing the border to Austria. If the vehicle has been traveling several kilometres on roads subject to toll before the driver acquires an OBU, the driver can pay the toll due for that distance at the	<a href="#">Link AT</a>	Yes (at the POS)	Yes (credit cards and fleet cards at the POS)	n/a	n/a

	nearest point of sale where he can also get a local OBU.					
<b>Poland (KAS)</b>	Download the mobile app “e-TOLL PL”. The App turns your mobile device into an OBE that can be used for toll collection in Poland. Please note that the mobile app must be linked with your own personal e-TOLL-account.	<a href="#">Link PL</a>	Yes (prepaid account charging at the POS)	Yes (linked with the end customers personal account)	No	Yes
<b>Portugal (APCAP)</b>	Use the alternative lane for manual toll collection on the motorways. Use cash or card to pay toll.		Yes	Yes	Yes	No
<b>Scandinavian bridges (Øresund &amp; Storebælt)</b>	Pay cash at the toll station. This applies for both the Øresund and the Storebælt bridges.		Ja (yellow lane)	Ja (blue and yellow lane)	Yes (yellow lane)	n/a
<b>Slovenia (DARS)</b>	Get a local prepaid OBU (DarsGO) issued by DARS. There are many sales points near roads subject to toll before crossing the border to Slovenia.	<a href="#">Link SI</a>	Yes (at the POS)	Yes (credit cards and fleet cards at the POS)	n/a	n/a
<b>Slovakia (NDS)</b>	Get a local OBU issued by Skytoll (prepayment and subsequent payment possible). Registration in advance is recommended but not necessary. The OBU can be picked up at a POS.	<a href="#">Link SK</a> <a href="#">Link POS</a>	Yes	Yes	No	No
<b>Switzerland (BAZG)</b>	As from 01/04/2025 the NMTS web shop solution makes manual registration for trips to the LSVA domain (Switzerland/Liechtenstein) possible without EETS/NETS solution. Each trip must be registered and paid online or cash before beginning the trip. Changes are possible before entering the domain, after that only limited changes are possible. Electronic payments can be corrected within 5 days after leaving the domain, then the invoice will be issued.	<a href="#">Link CH</a> <a href="#">Link LSVA</a>	Yes	Yes	Yes	No
<b>Spain (SEOPAN)</b>	Use the alternative lane for manual toll collection on the motorways. Use cash or card to pay toll.		Yes	Yes	n/a	n/a
<b>Czech Republic (CzechToll)</b>	Post-payments are possible by means of debit or fuel cards; refer to the national provider. The website shows the accepted fuels and bank cards.	<a href="#">Link CZ</a>	No	Yes	No	No
<b>Hungary (NUSZ)</b>	Buy a ticket online and at a point of sale.	<a href="#">Link HU</a>	Yes (at the POS)	Yes	n/a	Yes

## 8.3 Customer service

The menu item “[Customer service](#)” can show contact details of your Service Partner, e.g. a telephone number or a QR code with more contact details.

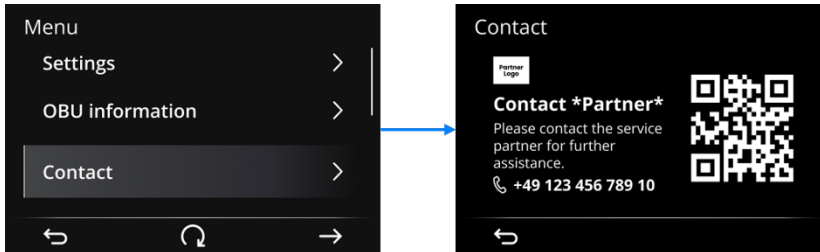

Figure 31: Customer service

# 09/

## Specific features of individual toll domains

### 9.1 Belgium (BEvia)

You find specific information regarding toll collection in the Belgian toll domain (more than 7,400 km) here:

[www.viapass.be/en/downloads/](http://www.viapass.be/en/downloads/)

#### Information regarding exemption from toll fees

Toll does not have to be paid for certain vehicles. An application for exemption has to be submitted to the relevant regional services. Please note:

[www.viapass.be/en/downloads/exemptions-clarified/](http://www.viapass.be/en/downloads/exemptions-clarified/)

#### Changeable parameters that are specific for the toll domain

For the toll domain of Belgium (BEvia) the driver does not have to change any parameters in the OBU.

#### Notes for classification in case of missing parameters

If the parameters “[permissible maximum total vehicle weight](#)” and “[Euro emission class](#)” are not available or insufficiently documented for a vehicle, the vehicle will be classified as shown below:

- vehicle weight as “total vehicle weight above 32 t” and
- vehicle category “Other Euro emission class”.

Evidence provided later, e.g. for the emission class, cannot be taken into account in retrospect.

### 9.2 Belgium Liefkenshoek-Tunnel (BElit)

For the Belgian Liefkenshoek tunnel no specific information for the toll domain has to be heeded.

You can find more information here:

<https://www.liefkenshoektunnel.be/en>

## 9.3 Bulgaria (BGria)

In Bulgaria, motorways, some lower category roads and some bridges and ferries are subject to toll - altogether approximately 6,000 km. Vehicles for goods and passenger transport with a permissible total weight of more than 3.5 t are subject to toll collection by means of a satellite supported toll system (GNSS).

<https://www.bgtoll.bg/de/> shows a description of the Bulgarian toll service.

### **Bulgarian language**

If the end customer needs information regarding the Bulgarian Toll Charger in the Bulgarian language, the customer can contact the following organization:

E-Mail: [support@tollpass.bg](mailto:support@tollpass.bg)

Telephone (Call center): +359884005500

### **Changeable parameters that are specific for the toll domain**

For the toll domain of Bulgaria (BGria) the driver has to update the following parameters on the OBU depending on the current state of the vehicle:

- Trailer axles

## 9.4 Denmark and Sweden

You will find specific information regarding toll collection in the toll domain of Denmark/Sweden for the Storebælt bridge here: <https://www.darsgo.si/portal/de/toll-price>

You will find specific information regarding toll collection in the toll domain of Denmark/Sweden for the Øresund bridge here: <https://www.oresundsbron.com/de/start>

### **Changeable parameters that are specific for the toll domain**

For the toll domain of Storebælt and Øresund the driver does not have to change any parameters in the OBU.

## Verification

The driver ensures that the OBU is installed correctly and observes the signals of the OBU. In case of issues (signs of a malfunction when passing a toll station) the driver has to contact the Service Partner.

## Sound signal

Each successful transaction will be indicated by the OBU with a sound signal when the barrier at the toll station opens.

## Vehicle declaration

In Denmark and Sweden, the driver is obliged to carry a vehicle declaration as shown in the example below. The drivers get these declarations from their Service Partner. Present the vehicle declaration to the staff at the toll station for identification in case the barrier does not open automatically.

The user is obliged to check the vehicle declaration before using the OBU. A new vehicle declaration must be acquired from the Service Partner in case of any change of the vehicle features (e.g. license plate number, Euro class, type of drive).

EETS On Board Unit	
<p><b>Vertragspartner / contract partner:</b> Sales Partner GmbH Road 3 12345 City Germany</p>	
<p><b>FAHRZEUGDEKLARATION VEHICLE DECLARATION</b></p>	
Ausstellungsdatum / Issuing Date	23/09/21 14:39:22
Kfz-Kennzeichen / License Plate	LPN123LPN
Nationalität / Nationality	CZ
PAN	608711523424523454235234
OBU S/N	000070001026996
OBU ID	9400070007000FABB4
Antriebsart / Engine Characteristics	4 - Diesel
Emissionsklasse / Euro Emission Class	6
Achszahl (Zugfahrzeug) / Number of Axles (Tractor)	2
Europäische Fahrzeugklasse / European Vehicle Class	5
Service Provider	Toll4Europe GmbH Nymphenburger Str. 3c 80335 München Germany

**Nur zur Verwendung an den Mautstellen Storebaelt (DK) und Öresund (SE/DK)!**  
Use at the toll plazas of Storebaelt (DK) and Öresund (SE/DK) only!

**Nutzungshinweise**

Bitte überprüfen Sie vor Fahrtantritt, ob die oben angeführte EETS On Board Unit in dem oben angeführten Kfz ordnungsgemäß montiert wurde. Die Fahrzeugdeklaration ist vom Fahrzeuglenker während der Fahrt mitzuführen. Durch jedwede Änderungen der oben angeführten, registrierten Daten verliert diese Fahrzeugdeklaration ihre Gültigkeit. Änderungen sind umgehend bekanntzugeben. Auskunft zur EETS On Board Unit erteilt ihr Vertragspartner. **Diese Fahrzeugdeklaration ist ausschließlich zur Verwendung an den Mautstellen Storebaelt (DK) and Öresund (SE/DK) vorgesehen.**

**OBU ID**



**Advice for usage**

Before starting your trip, please check if the above mentioned EETS On Board Unit has been mounted properly in the vehicle referred above. The vehicle driver must carry the vehicle declaration on the board during the trip. With any change of the above data this vehicle declaration loses its validity. Any changes have to be reported immediately. Information about your EETS On Board Unit will be delivered by your contract partner only. **This vehicle declaration shall only be used at the toll plazas of Storebaelt (DK) and Öresund (SE/DK).**

**PAN**



Figure 32: Vehicle declaration for Denmark and Sweden (DKbri)

## 9.5 Germany (DEbag)

For specific information on toll collection in the toll domain of Germany (more than 50,000 km of roads subject to toll) and

information on exemptions from toll collection see:

[https://www.balm.bund.de/DE/Themen/Verkehrswirtschaft/verkehrswirtschaft\\_node.html](https://www.balm.bund.de/DE/Themen/Verkehrswirtschaft/verkehrswirtschaft_node.html)

### **Changeable parameters that are specific for the toll domain**

For the toll domain of Germany (DEbag) the driver has to update the following parameters on the OBU depending on the current state of the vehicle:

- Number of trailer axles
- Permissible total weight of the vehicle train (current permissible total weight of tractor plus trailer)

**CO2 class:** The CO2 emission class of a vehicle from 1 to 5 in accordance with Art. 7ga, Directive 1999/62/EC as shown in the vehicle documents. If the value is unknown, the CO2 class is set as "0" and price calculation is performed on the basis of the worst and most expensive class "1".

**Axles:** The current total number of axles for the vehicle combination (tractor + trailer) is shown. It may vary depending on the trailer used. For this reason the driver has to enter the number of trailer axles in the OBU.

**Weight:** When coupling the trailer with the tractor, the new, actual permissible total weight of the vehicle train (tractor plus trailer) must be entered.

When selecting the weight range in the OBU menu (e.g.  $\geq 7.5$  t and  $<12$  t) the lower value is shown on the OBU display.

### **Exemptions for craftsmen (HWA)**

If you want to use the HWA occasionally while you would normally have to pay toll fees in Germany, we recommend you to deactivate the German toll service (BAG) before starting a trip in the capacity of craftsman. You have to switch the service on again before the next trip that is subject to toll.

As an alternative to deactivating the German toll service BAG you may choose the following:

The driver has to select the weight of  $\leq 3.5$  t on the OBU. Our [Video-Tutorial](#) shows how to select the weight. The OBU will continue showing a green status light.

We recommend to make this adjustment before each trip.

It is mandatory to set the correct total vehicle weight of more than 3.5 t (subject to toll) if the intended trip is not one as a craftsman since you may otherwise be fined.

We urgently recommend that the customer registers as craftsman with [TollCollect](#) and loads up respective proof beforehand to minimize controls by the authorities.

The registration mentioned above does not exempt the customer from the obligation to prove that they fulfil the legal requirements according to the HWA, for instance when they are controlled by the police, but they should be controlled less often.

Examples for weight indications on the OBU:

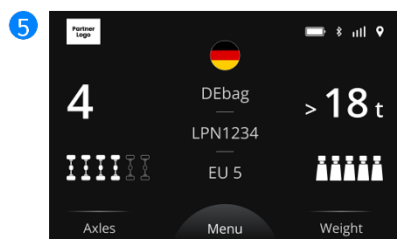
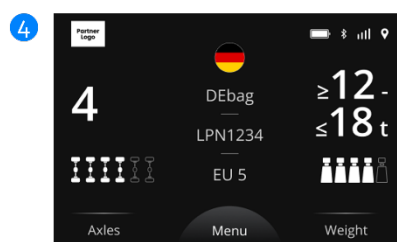
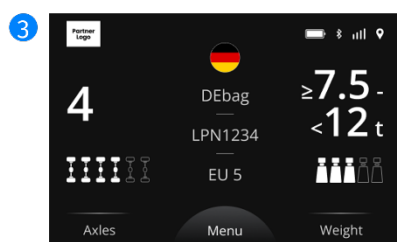
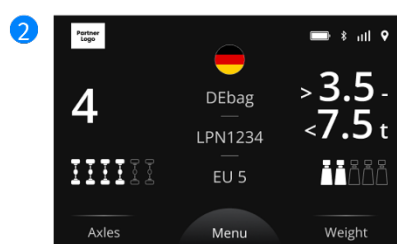
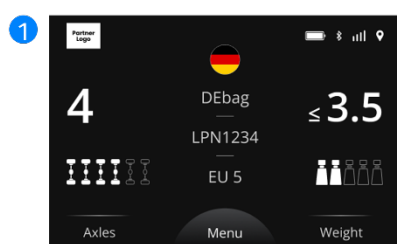

- 1 DEbag, weight smaller/equal 3.5 t → ≤ 3.5 t
- 2 DEbag, weight between > 3.5 t and < 7.5 t
- 3 DEbag, weight between ≥ 7.5 t and < 12 t
- 4 DEbag, weight between ≥ 12 t and ≤ 18 t
- 5 DEbag, weight more than 18 t → > 18 t

## 9.6 Germany Herrentunnel and Warnow tunnel (DEtun)

For the German tunnels Warnow tunnel and Herrentunnel no specific toll domain features have to be heeded.

You can find more information here:

<https://www.warnowquerung.de/tarife/>

<https://www.herrentunnel.de/index.php/maut-tarife.html>

## 9.7 France (FRtis)

The toll service of France covers all roads subject to toll in France (which are part of the TIS-PL system) and selected car parks; in total 9,300 km. You find information on specific toll features that apply in the toll domain of France TIS PL "Télépéage Inter-Sociétés Poids Lourds" (FRtis) under [www.autoroutes.fr](http://www.autoroutes.fr)



### Changeable parameters that are specific for the toll domain

For the toll domain of France (FRtis) the driver has to update the following parameters on the OBU depending on the current state of the vehicle:

- Trailer axles

The OBU also shows the permissible total weight (permissible maximum total weight of tractor plus trailer) and the emission class; they cannot be altered on the OBU.

### Different types of roads subject to toll

When driving on the motorway or leaving it, use the lane marked  or  if the former is not available.

If the lane has a low clearance warning bar, the lane is intended exclusively for use by light vehicles with a height of less than 2 m (category 1, light vehicles).

If the lane does not have a bar, it may be used by any vehicle.

There are also toll stations with lanes marked for speed "30" which allow a faster passage. On these lanes you may go at a speed of up to 30 km/h. The OBU will be automatically detected when you are driving on the toll lane and the OBU is correctly installed in the vehicle.

### Correct use of toll lanes

Drive at walking speed to ensure that the OBU can be detected (sound signal). Keep a distance of at least 4 metres from the vehicle in front of you. Look out for the green light to signal that passage through the barrier was successful. If the barrier is already open while you approach it, do not pass before you get green light. Look out for motorway staff who may cross the road.

### Correct use of free flow toll lanes

A free flow toll station is a toll station without barriers where the drivers have to stop. Please follow the TCH's instructions on the correct use of free flow toll lanes.

## 9.8 Italy (ITsit)

Specifications for toll collection in the toll service of Italy: the network covers the TCH and toll domains shown below with more than 6,000 km of roads subject to toll.

Issuer ID	Company
1	AUTOSTRADA BRESCIA-VERONA-VICENZA-PADOVA S.p.A.
6	AUTOSTRADE PER L'ITALIA S.p.A.
2	AUTOSTRADA DEL BRENNERO S.p.A.
28	SOCIETÀ AUTOSTRADA TIRRENICA p.A. (S.A.T.)
29	RACCORDO AUTOSTRADALE VALLE D'AOSTA S.p.A. (R.A.V.)
23	TANGENZIALE DI NAPOLI S.p.A.
64	Salerno Pompei Napoli S.p.A. (previously: Autostrade Meridionali, issuer id 10)
78	Società Autostrade Alto Adriatico S.p.A. (previously: Autovie Venete, ID 9)
54	CONCESSIONI AUTOSTRADALI VENETE S.p.A. (C.A.V.)
5	STRADA DEI PARCHI S.p.A.
43	AUTOSTRADA ASTI-CUNEO S.p.A. (ATCN)
14	Società Autostrada Torino Alessandria Piacenza S.p.A. (S.A.T.A.P.) (A4)
49	Società di Progetto Autovia Padana S.p.A. (S.A.P.)
17	SOCIETÀ AUTOSTRADE VALDOSTANE S.p.A. (S.A.V.)
11	SOCIETÀ AUTOSTRADA LIGURE TOSCANA S.p.A. (S.A.L.T.) (A15)
26	AUTOSTRADA DEI FIORI S.p.A. (ADF) (A6)
74	Concessioni del Tirreno A12 S.p.A. (previously: ID 8)
75	Concessioni del Tirreno A10 S.p.A. (previously: ID 18)
27	SOCIETÀ ITALIANA TRAFORO AUTOSTRADALE DEL FREJUS S.p.A. (S.I.T.A.F.)
97	Ivrea Torino Piacenza S.p.A.- A21 (previously: SATAP, ID 15)
98	Ivrea Torino Piacenza S.p.A. - A5 (previously: ATIVA, ID 21)
80	Società di Progetto BREBEMI S.p.A. ( <i>Società di Progetto Autostrada Diretta Brescia Milano</i> )
81	Tangenziale Esterna S.p.A. (T.E.) S.p.A.
7	MILANO SERRAVALLE-MILANO TANGENZIALI S.p.A.
82	Autostrada Pedemontana Lombarda S.p.A.
41	Superstrada Pedemontana Veneta S.p.A.

The toll domain "ITsit" covers the Toll Chargers and toll domains listed in the table above with the following exceptions:

- Montblanc Tunnel (Societa'italiana per azioni per il traforo del Monte Bianco),
- Great St Bernhard Tunnel (Societa'italiana traforo Gran San Bernardo S.p.A.),
- Frejus Tunnel (Societa' Italiana Traforo Autostradale Del Frejus S.I.T.A.F.),
- \*the above mentioned toll domain 21 of the TCH
  - „Consortio per le Autostrade Siciliane“ (A18, A20).

### **Changeable parameters that are specific for the toll domain**

For the toll domain of Italy (ITsit) the driver has to update the following parameters on the OBU depending on the current state of the vehicle:

- Number of trailer axles

### **Important information regarding failed payments in semi-closed systems – “Mancato Pagamento”:**

If the traffic light turns red and/or the barrier does not open while passing a toll station on a lane reserved exclusively for the electronic toll service, the driver must stop and push the “help” key on the column to request support. In this case the TCH starts the credit reclamation procedure (“Mancato Pagamento”). For driving on all other types of motorways payment can be made as usual (cash and/or approved cards).

The driver will be issued a "Rapporto di Mancato Pagamento Pedaggio - RMPP" (in English: Record of missing payment) if a toll payment device (Toll4Europe OBU) cannot be used when leaving the toll domain. In this case the driver receives the “Mancato Pagamento” and has to make a subsequent payment. The reason may be a failed OBU registration or that a wrong lane was used.

No electronic trip data will be recorded for these manual transactions. The customer is liable for making the payment within the time limit indicated (between 5 and 15 days). Non-payment will lead to large fines.



Figure 33: Sample for an outstanding payment

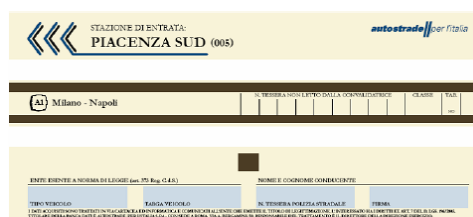

Figure 34: Sample for a toll ticket

## 9.9 Austria (ATasf)

You find specific information regarding the toll domain of Austria (more than 2,200 km) here: [www.asfinag.at/toll/go-box-for-hgv-and-bus/european-electronic-toll-service/](http://www.asfinag.at/toll/go-box-for-hgv-and-bus/european-electronic-toll-service/)

### Changeable parameters that are specific for the toll domain

For the toll domain of Austria the driver has to update the following parameters on the OBU depending on the current state of the vehicle:

- Number of trailer axles

### Verification

The driver ensures that the OBU is installed correctly and he observes the signals of the OBU. In case of issues (signs of malfunctioning when passing a toll station) the driver has to contact the Service Partner.

### Sound signal

Each successful transaction when passing a toll station will be indicated by the OBU by means of a sound signal. When no sound signal occurs after a passage, the driver has to go to the nearest Go Maut sales point.

### Vehicle declaration

In Austria, the driver is obliged to carry a vehicle declaration similar to the example provided below. It must be presented for identification during controls. The vehicle declaration is provided by the Service Partner.

The user is obliged to check the vehicle declaration before using the OBU. Whenever a vehicle feature was altered (e.g. license plate number, Euro class, type of drive), the Service Partner must hand over a new vehicle declaration.



Nur zur Verwendung im österreichischen Mautgebiet! Use in the Austrian toll system only!	
<b>EETS On Board Unit</b>	
<b>Vertragspartner / contract partner:</b> Sales Partner XYZ Teststraße 1 AT-8010 Graz Austria	
FAHRZEUGDEKLARATION VEHICLE DECLARATION	
Ausstellungsdatum Issuing Date	2025-01-14 16:18:10
Kfz-Kennzeichen License Plate	VEHICLE2
Nationalität Nationality	DE
PAN	608711000000044444
OBUS/N	000413954181348
OBUID	9400280029EB8004E6
Antriebsart Engine Characteristics	4 - Diesel
CO2-Klasse mit Gültigkeit CO2 class with validity period	2   2025-01-14 - 2030-11-20
Emissionsklasse Euro Emission Class	6
Achszahl (Zugfahrzeug) Number of Axles (Tractor)	2
Europäische Fahrzeugklasse European Vehicle Class	3 (Bus)
Service Provider	Toll4Europe GmbH Nymphenburger Str. 3c 80335 München, Germany
<b>Nutzungshinweise</b> Bitte überprüfen Sie vor Fahrtantritt, ob die oben angeführte EETS On Board Unit in dem oben angeführten Kfz ordnungsgemäß montiert wurde. Die Fahrzeugdeklaration ist vom Fahrzeuglenker während der Fahrt mitzuführen. Durch jedwede Änderung der oben angeführten, registrierten Daten verliert diese Fahrzeugdeklaration ihre Gültigkeit. Änderungen sind umgehend bekanntzugeben. Auskunft zur EETS On Board Unit erteilt Ihr Vertragspartner.	
<b>Diese Fahrzeugdeklaration ist ausschließlich zur Verwendung mit dem österreichischen Mautsystem der ASFINAG vorgesehen.</b>	
OBU ID 	
<b>Advice for usage</b> Before starting your trip, please check if the above mentioned EETS On Board Unit has been mounted properly in the vehicle referred above. The vehicle driver must carry the vehicle declaration on the board during the trip. With any change of the above data this vehicle declaration loses its validity. Any changes have to be reported immediately. Information about your EETS On Board Unit will be delivered by your contract partner only.	
<b>This vehicle declaration shall only be used in the Austrian toll collection system ASFINAG.</b>	
PAN 	

Figure 35: Vehicle declaration for Austria

## 9.10 Polen (PLeto)

Specifications for the toll service in Poland are provided here:

<https://etoll.gov.pl/en/heavy-vehicles/>

- The e-TOLL system in Poland is applicable for all vehicles with a permissible maximum total weight above 3.5 t.
- The e-TOLL system covers the state toll roads in Poland with a total of more than 5,200 km of motorways and high speed roads.
- Tariffs depend on the Euro emission class, the permissible maximum total weight of the vehicle combination and on the vehicle type (bus/truck).

### Changeable parameters that are specific for the toll domain

For the toll domain of Poland the driver has to update the following parameters on the OBU depending on the current state of the vehicle:

- Current total weight of the vehicle train (GTW): The current total weight of the vehicle train (GTW) is the permissible maximum combined weight of the tractor and the currently coupled trailer.

## 9.11 Portugal (PTvve) and Spain (ESvia)

You will find specific information regarding toll collection in the toll domain of Spain (ESvia) for approximately 1300 km here: [www.viat.es](http://www.viat.es)

You will find specific information regarding toll collection in the toll domain of Portugal (PTvve) for approximately 2900 km here: [www.viaverde.pt](http://www.viaverde.pt)

Toll lanes: In Portugal you have to use the lane marked “ViaVerde” were the vehicle is detected and the toll data are automatically transferred to the Service Partner for toll calculation.

### **Changeable parameters that are specific for the toll domain**

For the toll domains of Spain and Portugal the driver has to update the following parameters on the OBU depending on the current state of the vehicle:

- Number of trailer axles

### **Correct use of toll lanes (Spain)**

Drive at walking speed to ensure that the OBU can be detected (sound signal). Keep a distance of at least 4 m from the vehicle in front of you. Look out for the green light to signal that passage was successful. If the barrier is already open while you approach it, do not pass before you get green light. Look out for motorway staff who may cross the road.

### **Correct use of toll lanes (Portugal)**

ViaVerde lanes do not have barriers and vehicles must not go faster than 60 km/h. Keep a distance of at least 4 m from the vehicle in front of you. Look out for the green light to signal that passage was successful. Look out for motorway staff who may cross the road.

### **Correct use of “free flow” highways**

These highways are equipped with toll bridges. When approaching these bridges you can keep going at normal speed. Please respect the maximum speed defined for the highway.

## 9.12 Switzerland (CHlsv)

You will find specific information regarding toll collection in the toll domain of Switzerland here:

<https://www.ezv.admin.ch/ezv/en/home/information-companies/transport--travel-documents--road-taxes/heavy-vehicle-charges--performance-related-and-lump-sum-.html>

- Toll in Switzerland (LSVA - performance related heavy goods vehicle supplement) is a federal tax charged on the basis of **total weight, emission class and distance covered (in kilometres)**.
- The T4E EETS can be used for the performance related heavy goods vehicle supplement for vehicles that are **not registered in Switzerland or Liechtenstein**.
- The toll will be charged for the entire public road system (approximately 85,000 km) of
  - Switzerland;
  - the Principality of Liechtenstein;
  - the German enclave of Büsingen;
  - the Italian enclave of Campione d'Italia;
  - on the toll road Basel - Mulhouse Airport.
- It does not cover the tunnel "Great St Bernhard".



Every kilometre will be counted and is subject to toll as soon as you enter Switzerland. All road types are subject to toll.

### Changeable parameters that are specific for the toll domain

For the toll domain of Switzerland (CHlsv) the driver has to update the following parameters on the OBU depending on the current state of the vehicle:

- Trailer weight
- Number of trailer axles
- Transport mode

Please note Chapter 5. Configuration.

### Trailer weight declaration

Trailer declaration will lead to different tariffs depending on the weight and type of trailer. The so-called "relevant weight" is calculated as follows:

- For trucks with a trailer:  
total weight of the tractor (F2) plus total weight of the trailer (F2)  
or
- For a tractor with a semi-trailer:  
empty weight (tare) of the tractor (G) plus total weight of the semi-trailer (F2).
- If the combination of tractor and trailer exceeds the national weight limit (max. 40 t), 40 t will be used as relevant weight.

### Transport mode

When the truck is carried by a train, the driver has to put the OBU in transport mode to avoid fees. For detailed information see Chapter 5.4.2 Transport mode.

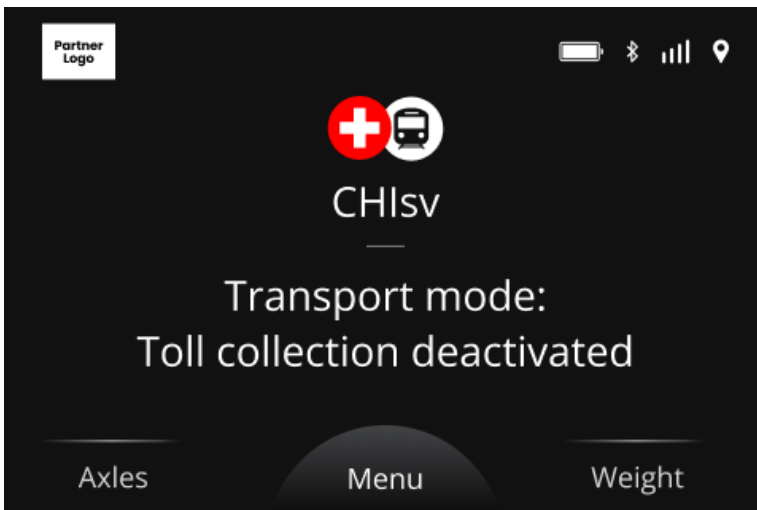

Figure 36: Transport mode

## 9.13 Slovakia (SKmyt)

You will find specific information regarding toll collection in the toll domain of Slovakia with approximately 850 km here:

<https://www.darsgo.si/portal/de/toll-price>

- The toll system in Slovakia applies for all vehicles with a permissible maximum total of more than 3.5 t.
- The toll system covers the state toll roads in Slovakia with a total length of more than 17,700 km.
- Tariffs depend on road class, EURO emission class, the permissible maximum total weight of the vehicle combination, the vehicle type (bus/truck) and the number of axles of the vehicle subject to toll. For fully electric vehicles applies the same

toll tariff as for vehicles with the best emission class (lowest emissions).

#### **Changeable parameters that are specific for the toll domain**

For the toll domain of Slovakia the driver has to update the following parameters on the OBU depending on the current state of the vehicle:

- Number of trailer axles

## 9.14 Slovenia (Sldar)

You will find specific information regarding toll collection in the toll domain of Slovenia with more than 600 km here:

<https://www.darsgo.si/portal/de/toll-price>

#### **Changeable parameters that are specific for the toll domain**

For the toll domain of Slovenia the driver has to update the following parameters on the OBU depending on the current state of the vehicle:

- Number of trailer axles

#### **Verification**

The driver ensures that the OBU is installed correctly and observes the signals of the OBU. In case of issues (signs of malfunctioning when passing a toll station) the driver has to contact the Service Partner.

#### **Sound signal**

Each successful transaction when passing a toll station will be indicated by the OBU by means of a sound signal. When no sound signal occurs after a passage, the driver has to go to the nearest DarsGo sales point.

## 9.15 Hungary (HUgo)

In the distance-based toll system HU-GO in Hungary toll must be paid for all trucks and tractors with a permissible total weight of more than 3.5 t, tractors (including those for semi-trailers) and all combinations of articulated vehicles consisting of such a vehicle and a towed trailer or a semi-trailer. Toll is to be paid on motorways and some highways. The electronic HU-GO system is a satellite-based system (GNSS).

You will find specific information regarding toll collection in the toll domain of Hungary here: <https://www.hungo.hu/articles/category/news>

### Changeable parameters that are specific for the toll domain

For the toll domain of Hungary (HUgo) the driver has to update the following parameters on the OBU depending on the current state of the vehicle:

- Number of trailer axles

Please note the following when changing the number of axles:

After the number of axles was changed in Hungary (in Hungary only), the OBU transmits the change to the backend. Normally the backend confirms the new number of axles quickly. However, if it takes more than 15 seconds (e.g. because GPRS reception is poor), the OBU status indicator will turn **red** and a warning will appear "Number of axles changed Transmission ongoing". In this case the driver has to wait before continuing the trip until the OBU status indicator turns **green** and the message disappears.



Figure 37: Number of axles changed.

# 10/

## OBU-User Interface

### 10.1 Menu Structure

The images in the menu overview below are examples only and may deviate from the actual menu.

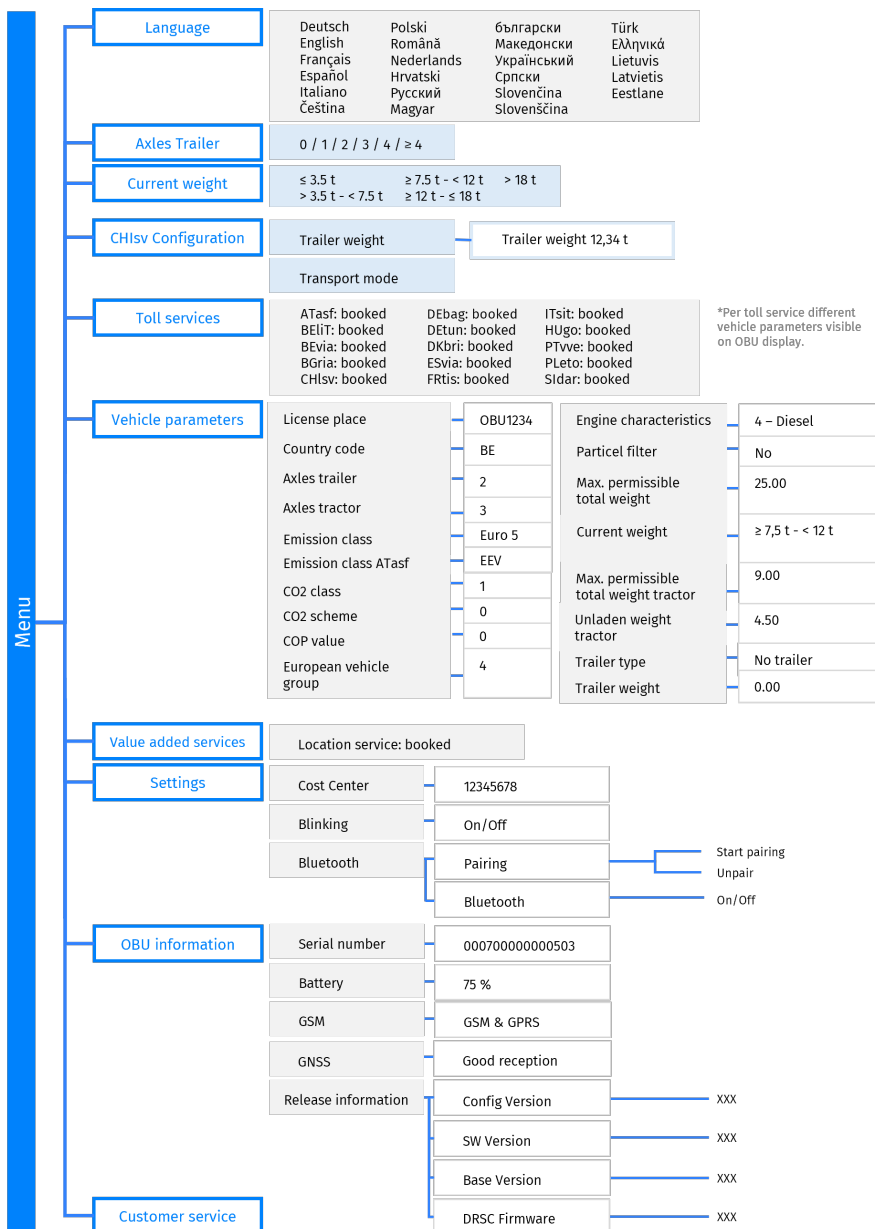

Figure 38: Menu structure

## 10.2 Settings

Under “Settings” the user can make the following configurations:

- Cost centre (for Germany only)
- Blinking and
- Bluetooth

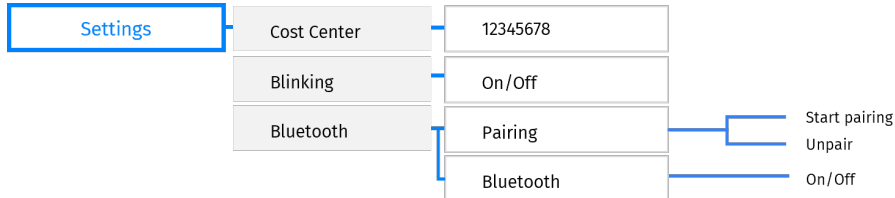

Figure 39: Menu structure “Settings”

### Cost centre entry

Entering the cost centre is optional. The number stored here can be found on the invoice for road charges in Germany and makes it easier to assign the costs to an order.

Here you may enter a cost centre number if you want. Use the following characters (up to 8): letters A-Z, figures 0-9, special characters (-) minus, (,) comma, (.) full stop and space.

You can select the characters with the navigation wheel. Save the entry by pressing the centre of the navigation wheel or the bottom right navigation key.

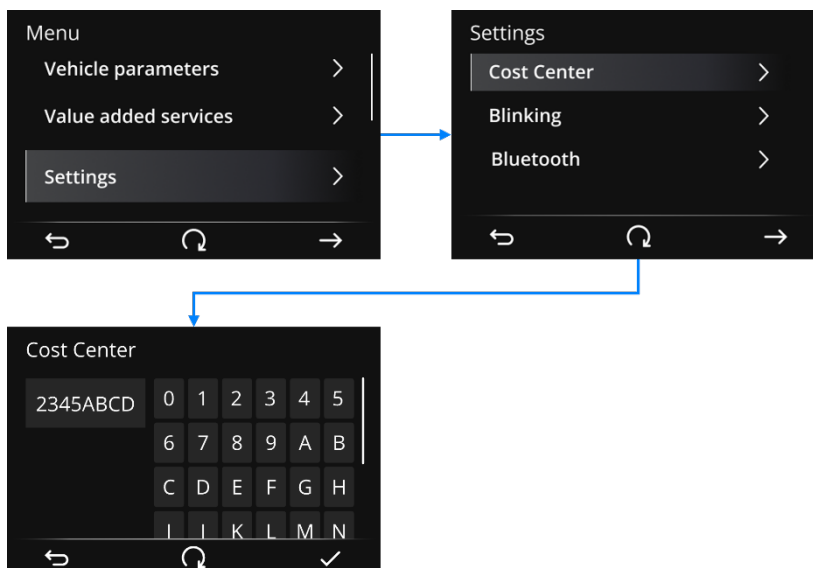

Figure 40: Cost centre configuration

## How to configure Blinking

The menu has an option to configure the blinking of the LED that occurs normally when the light is red or yellow. The default setting for blinking is On. You can deactivate it in the menu. Press the navigation key at the bottom right for confirmation (“ok”).

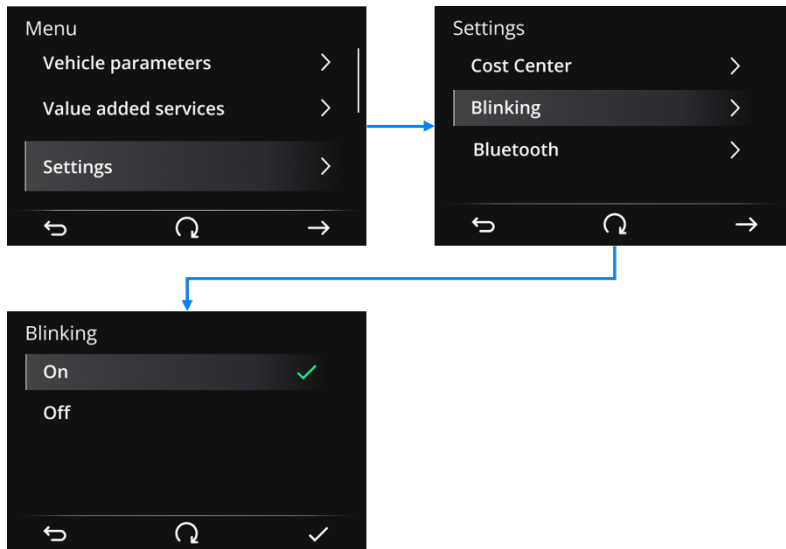

Figure 41: How to configure blinking

## Bluetooth configuration

Access to the menu item “Bluetooth” offers the options (1: Coupling) for connection with/disconnection from a mobile device (e.g. smartphone) or (2: Bluetooth status) for changing the current Bluetooth status (ON/OFF). To make a selection press the bottom right key (“ok”); press the key at the bottom left to return to the previous level.

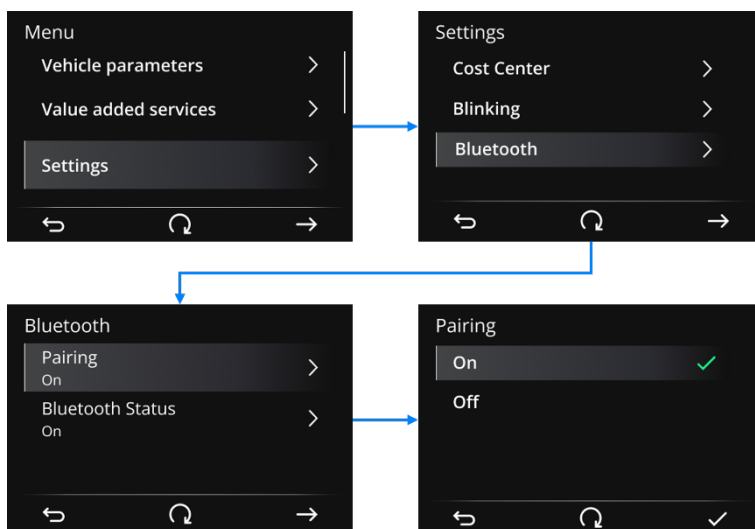

Figure 42: Bluetooth configuration

### *Coupling*

When starting the Bluetooth coupling process a Bluetooth PIN is generated which will be shown temporarily on the user interface. After entering and confirming the PIN on a smartphone, the OBU and the smartphone will be connected. (Note: The Bluetooth coupling process will be aborted if there is no activity). In contrast to this all existing couplings (previous connections) will be deleted from the OBU Bluetooth module when you select “Delete coupling”.

The OBU can connect again with known devices; you don't need to couple them again.

### *Bluetooth status*

The user can activate/deactivate the Bluetooth module to allow/prohibit any (existing/new) connections with another device. The default setting of the Bluetooth module is OFF.

For accessing all Bluetooth functions you can download and install a smartphone app for Android from the Google Play Store



## 10.3 Show OBU information and software version

Under the menu item “OBU Information” you can review information like the OBU serial number, battery information and other information related to your device.

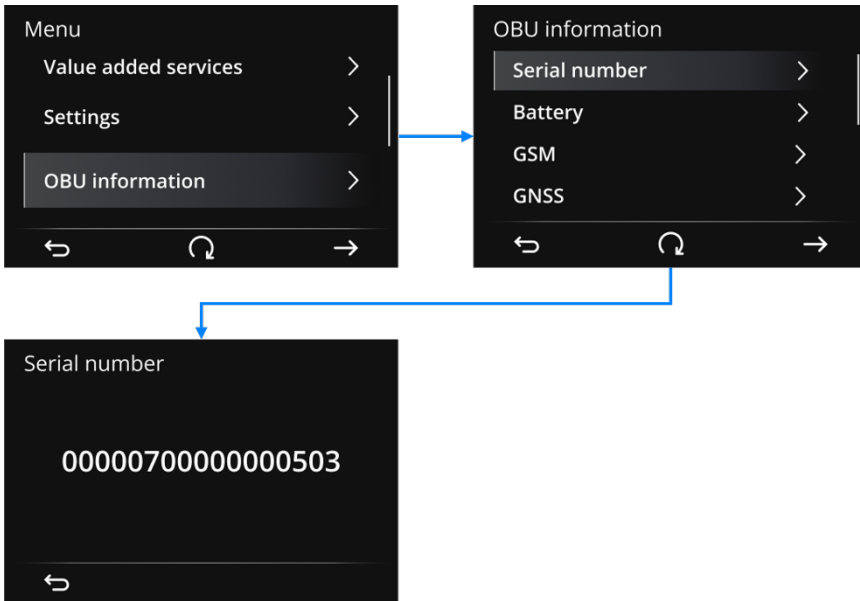

Figure 43: OBU information

# Technical Data

Operating temperature	-20 °C up to +60 °C
Long term storage temperature	Room temperature (10 – 20 °C)
Power supply	Fixed installation or plugged into the cigarette lighter socket Voltage 8-32 V Overvoltage protection  Removable battery (three hours of operation when active and up to seven days in standby mode)
Buffer battery	Round cell battery, nominal voltage = 3.0
Rechargeable battery	Lithium ion battery with a nominal voltage of 3.6 V, nominal capacity 1800 mA Duration of charging: 4 hrs. at 3.0 V to 4.05 V
Typical power consumption	Standby mode: 25 mW. Operation: 200 mA.
Supported systems:	GNSS: L1 Single band standard precision   support for all configurations and supplementary systems relevant in Europe: GPS, GLONASS, Galileo, EGNOS, Assisted GPS  highly sensitive 12-channel GPS receiver with internal antenna GSM: GPRS-enabled Quad Band GSM-module (Multislot class 10)  DSRC: Supports CEN- and ETSI-Standards: EN 15509, ISO 14906, ETSI ES 200 674-1, ISO 12813, ISO 13141  Wide beam antenna, specifically for mobile applications  Enhanced HF-immunity
Dimensions	122 × 118 × 40 mm
Weight	250 g
Colour	RAL 9004
Protection class	IP41

## Conformity declaration



0408

The T4E-OBU is on conformity with the European Directives 2014/53/EU (RED) and 2011/65/EU (RoHS).



10R – 04 0012

The OBU fulfils the requirements of ECE-regulation no. 10.5 – Electromagnetic compatibility EMC standard for vehicles UN ECE R10 (E-mark)